

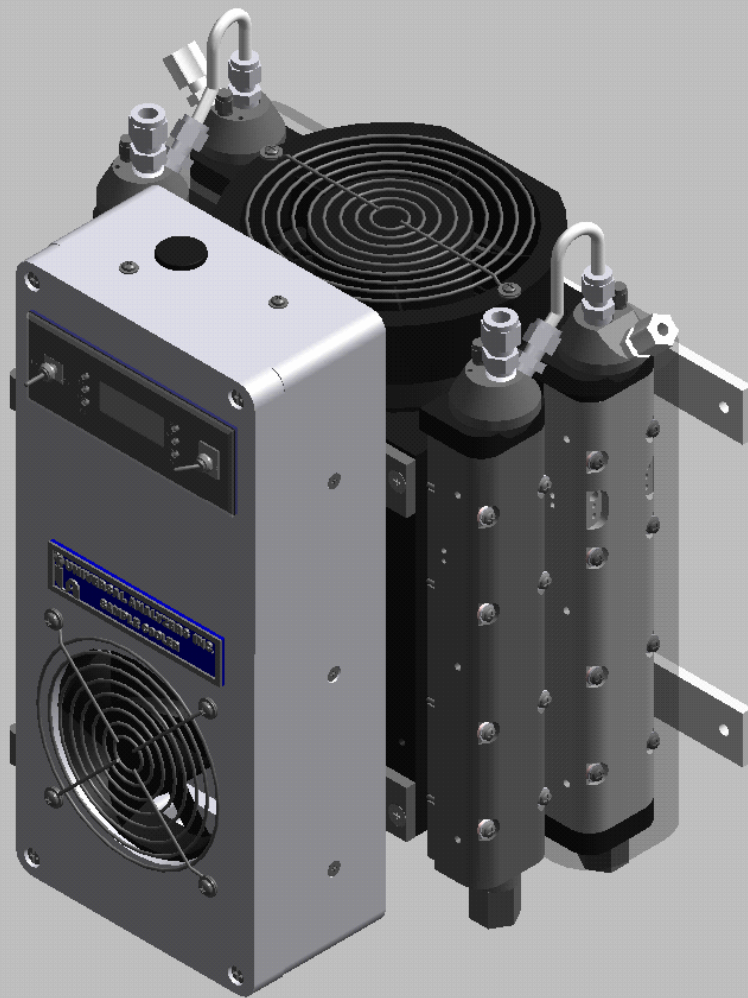

# *MODEL 1090*

## DUAL CHANNEL SAMPLE COOLER





## **LIMITED WARRANTY**

ALL PRODUCTS MANUFACTURED BY UNIVERSAL ANALYZERS INC. ARE WARRANTED TO BE FREE OF MANUFACTURING DEFECTS FOR A PERIOD OF ONE YEAR FROM THE DATE OF RECEIPT AT THE CUSTOMER'S RECEIVING AREA AND FOR AN ADDITIONAL PERIOD OF UP TO 90 DAYS IF THE PRODUCT IS PLACED IN SERVICE AFTER BEING IN STORAGE. THIS WARRANTY COVERS MATERIALS AND LABOR TO RESTORE ANY PRODUCTS TO ORIGINAL FACTORY SPECIFICATIONS IF A DEFECT IS FOUND WITHIN THE WARRANTY PERIOD.

THE DEFECTIVE PRODUCT SHOULD BE SENT, FREIGHT PREPAID, TO THE FACTORY IN CARSON CITY, NEVADA. REPAIRS WILL BE PERFORMED AT THE FACTORY AND RETURNED, PREPAID, BY THE SAME SHIPPING METHOD USED TO SEND THE PRODUCT TO THE FACTORY.

THIS WARRANTY DOES NOT APPLY WHERE THE EQUIPMENT HAS SUSTAINED DAMAGE DUE TO NEGLIGENCE, MODIFICATION, CORROSION, OR OTHER REASON BEYOND THE SCOPE OF THE NORMAL DEFINITION OF "MANUFACTURING DEFECT".

FURTHER, THIS WARRANTY IS LIMITED TO REPLACING THE DEFECTIVE COMPONENTS AND RETURNING THE EQUIPMENT MANUFACTURED BY UNIVERSAL ANALYZERS INC. TO THE CUSTOMER IN WORKING CONDITION. ANY OTHER CLAIMS ARE OUTSIDE THE SCOPE OF THIS WARRANTY. NO WARRANTIES ARE MADE AS TO THE SUITABILITY OF THE USE OF THE EQUIPMENT IN ANY PARTICULAR APPLICATION OR LOCATION. THE SUITABILITY OF THE USE OF THE EQUIPMENT IS THE RESPONSIBILITY OF THE CUSTOMER AND THE INSTALLING CONTRACTOR.

# Universal Analyzers Inc.

## UNIVERSAL ANALYZERS MODEL 1090 SAMPLE COOLER SPECIFICATIONS

SAMPLE FLOW RATE:	0 TO 20 L/M TOTAL (at STP)
TWO SAMPLE PATHS INDEPENDENTLY TEMPERATURE CONTROLLED, 10 L/M EACH.	
MAXIMUM INLET TEMPERATURE:	
STAINLESS STEEL HEAT EXCHANGER:	700° F. (351° C.)
KYNAR/GLASS HEAT EXCHANGER:	280° F. (138° C.)
MAXIMUM INLET GAS DEWPOINT:	178° F. (81° C.)
MAXIMUM INLET WATER CONCENTRATION:	50%
MINIMUM AMBIENT TEMPERATURE:	34° F. (1° C.)
MAXIMUM AMBIENT TEMPERATURE:	105° F. (41° C.)*
MAXIMUM COOLING POWER (SECOND STAGE):	252 BTUs PER HOUR (240 kJ/Hr.)
GAS DEW POINT LEAVING FIRST STAGE:	AMBIENT PLUS 18° F. (10° C.)
OUTLET SAMPLE DEW POINT:	41° F. (5° C.)
GAS SAMPLE INLET FITTINGS:	3/8" TUBING FITTINGS
GAS SAMPLE OUTLET FITTINGS:	1/4" TUBING FITTINGS
BOTTOM WATER DRAIN FITTINGS:	3/8" TUBING FITTINGS
MAXIMUM INPUT POWER:	740 WATTS
VOLTAGE:	90-132 or 180-264 VAC, 50/60 Hz
ELECTRICAL CLASSIFICATION:	GENERAL PURPOSE, NEMA 1
DIMENSIONS:	15" HIGH x 12" WIDE x 12 DEEP
WEIGHT:	38 LBS (17 KG)
SOLUBLE GAS REMOVAL RATES:	NO      0% LOSS NO <sub>2</sub> <10% LOSS SO <sub>2</sub> < 2% LOSS CO     0% LOSS CO <sub>2</sub> < 2% LOSS

\* at reduced flow rate above 77° F. (25° C.) ambient.

# UNIVERSAL ANALYZERS MODEL 1090 SAMPLE COOLER OPERATING INSTRUCTIONS

## APPLICATION

In order to sample combustion product stack gas or exhaust from Internal Combustion (IC) engines, a method to remove moisture from the sample without removing gas components of interest is a must. The Universal Analyzers Peltier Effect Sample Cooler is an ideal way to decrease the dew point of combustion gasses to a repeatable, stable, constant low dew point. The Universal Analyzer Gas Sample Coolers prevent water condensation in sample prefilters, sample pumps, and gas analyzers. For gas analyzers where water vapor is an interferent, a stable, repeatable dew point becomes a part of the gas analyzer's performance specification. The Universal Analyzers sample cooler provides this constant water concentration resulting in an accurate analysis of the components of interest.

The gas sample to be analyzed is brought to the sample cooler, first through a sample probe which usually contains a heated filter, and then through a heated sample line which keeps the sample above its dew point. The Universal Analyzers Sample Cooler then condenses water from the sample which lowers the dew point to 5 degrees C. (41 degrees F.). Particulate matter which escaped being filtered by the heated stack filter and which passes through the sample cooler can be removed by a visible sample prefilter, available from Universal Analyzers, located downstream from the sample cooler.

A gas sample pump should be provided as part of the sampling system. If the sample pump is placed ahead of the sample cooler, it should be provided with a heated head to avoid the condensation of water vapor due to the pump being below the dew point temperature of the sample. More commonly, the sample pump will be placed after the sample cooler in order to draw the sample through the cooler so that it has been dehydrated before the sample passes through the pump.

A means to control the flow of the sample through the system should be available and visible to the operator. This could be accomplished through the use of pressure regulators with gauges, flowmeters, and/or flow control needle valves.

Condensate removal from the heat exchanger(s) within the Sample Cooler can be accomplished through one of the following alternative methods:

1. A continuously running peristaltic tubing pump.
2. Installing the heat exchanger as a bypass condenser, pulling excess sample through with an eductor.
3. Using float drain traps similar to a steam trap. This requires the sample within the cooler to be at a positive pressure.
4. Use of drain pots on level control with a removal pump.

## DESCRIPTION

The Model 1090 can condition two independent gas sample streams to remove the moisture in two parallel paths. Two dual stage heat exchange systems are provided. The first stage of cooling in each path is at ambient temperature. Each second stage is cooled thermoelectrically and controlled with independent temperature sensors and control circuitry.

The key to the success of the Universal Analyzers Sample Cooler being able to condense the water from a wet gas sample with a minimal loss of the water soluble gas fraction, is due to the design of the heat exchanger. The separation occurs in a classical impinger which has a highly polished cylindrical surface cooled to the desired dew point temperature. The gas sample is brought to the bottom of the cylinder through an insulated tube and allowed to rise through a narrow annular area at a relatively high Reynolds number to insure the entire sample is influenced by the cold surface. The condensate falls down the cold polished surface in the form of a sheet (as opposed to droplets or the bubbling of the gas sample through the condensate) which minimizes the surface area in contact with the gas sample.

The temperature of the cylindrical condensation surface of the heat exchangers are maintained through intimate contact with aluminum heat transfer blocks. In the Model 1090 Sample Cooler, the first of the heat transfer blocks in each line is cooled by direct contact with the fan cooled heat sink. The temperature of the first of the two heat exchangers will be about 18° F above the temperature of the air passing through the heat sink when under full load conditions. (The temperature differential depends on the amount of heat that is being extracted from the sample, which is a function of the water content of the sample.)

The second of the heat exchangers in each line is cooled by the use of thermoelectric elements to a controlled temperature of 5° C. The temperature sensors are type “K” thermocouples. The controllers are proportional controllers with a proportional band of one degree C. The set points are factory set but field adjustable (0° - 25° C.) by opening the enclosure to reach the set point potentiometers. A momentary snap action switch on the front panel changes the temperature display to read the control set point temperature for each of the thermoelectrically cooled heat transfer blocks.

The fan cooled heat sink is constructed from anodized pure aluminum fins which carry and transfer heat to the air which is pulled through the heat sink with a high capacity fan. The pure aluminum material is a far better conductor of heat than the aluminum alloys which are normally used for extruded heat sinks. The result is an assembly which has superior heat exhausting capabilities under high ambient temperature conditions.

Universal Analyzer Thermoelectric Sample Coolers have a digital display as a front panel indication of the operating temperatures of each of the thermoelectrically cooled heat transfer blocks (switch selectable) in degrees Centigrade. Two internal jumpers at the top of the control circuit board within the enclosure can be moved to change the indicated temperature to read out in degrees Fahrenheit.

In addition, there are three LED lamps to indicate the status of each side of the cooler. The "COOL" lamps are green LEDs which light when the operating temperature falls below the factory set temperature of 10° C. "Over-temperature relays" are powered when each of the "Cool" lamps are on. The relay board within the enclosure has terminal strips to allow the relay contacts to be accessed for alarm purposes. The sample pump(s) can be interlocked with this relay.

The "DRY" lamps are green LEDs which indicate that there is no water in contact with the moisture sensors listed as the "WCO" or "WCOF" options. If no moisture sensors are used, these lamps should be turned off by installing jumpers on the moisture sensor input terminals on the relay board. Without moisture sensors installed, the "DRY" lamps have no meaning. The moisture sensor relay which is energized in the "dry" condition can be used to provide contacts to activate an annunciator panel and/or turn off the sample pump(s) in the "wet" condition.

The "TC" lamps are red LEDs which come on if there is an open connection in either of the temperature control thermocouples. If one turns on, it is an indication of temperature problems. The associated "over-temperature" relay will also transfer to the high temperature condition if the red "TC" lamp comes on.

The WCO or WCOF option available with the Universal Analyzers Sample Cooler is a sensor which detects the presence of liquid water. It is to be placed in each gas sample stream after the cooler, directly ahead of the visible sample filter to provide an alarm if condensate is found for any reason downstream from the sample cooler. The electronics associated with water carry-over sensors is included as a standard part of all Universal Analyzers Thermoelectric Sample Coolers. Two "Form C" relay contact sets are provided for each moisture sensor which transfer if water is present on the surface of the sensor.

## **INSTALLATION INSTRUCTIONS**

Installation shall be in accord with the manufacturer's instructions and the National Electrical Code (ANSI/NFPA 70).

Thermoelectric Sample Coolers should be installed away from heat sources in a well ventilated area of an instrument rack or enclosure. Completely enclosing any instrument generating 740 watts of energy will cause the temperature of the interior of the enclosure to rise to too great a level for the sample cooler to perform reliably. Universal Analyzers supplies NEMA 12 type enclosures modified to duct outside air directly into the heat sink. The heated air is then exhausted to the outside of the enclosure with two fans, thermostatically controlled. The interior of the enclosure is also insulated to reduce the solar heat loading in case the enclosure is mounted in the sun.

If two independent samples are to be chilled, sample tubing from each sampling point should be brought to each heat exchanger. A 3/8" tubing fitting is provided at the top of each of the first stage heat exchangers for the sample inlets to the sample cooler.

If a single sample is to be conditioned and both sides are to be used in order to handle a high sample flow rate, the two sides must be connected in parallel. When connecting the two sides in parallel, the tubing lengths should be selected to equalize the pressure drop at the inlets and outlets so the flow rates through each side will be approximately equal. Connected in this fashion will allow a maximum flow rate of 15 liters per minute. The dry sample outlets from the second stages are "1/4" tubing fittings coming out of the top at an angle.

Each sample should flow through an additional filter (with a clear bowl for checking the condition of the filter) as a safety measure before entering the analyzer(s).

A sample pump is normally required to pull the sample through the sample cooler and to force it through the visible filter. Moisture sensors, if used should be located ahead of the visible filters or should be incorporated as part of the visible filters.

A 3/8" tubing fitting is provided as the condensate drain connection at the bottom of each heat exchanger. This can be removed to expose 3/8" NPT female connections. Equipment required to remove the condensate must be installed. Several methods are discussed above. If peristaltic pumps are used and if two separate samples are cooled, the usual requirement will be for two dual head pumps or four single head pumps, one head for each heat exchanger.

In the special case where the 1090 is used for cooling a single gas sample stream and if the sample is split between the two sides with tees at the inlet and outlet, a single dual head peristaltic pump will be sufficient to remove the water from the sample cooler. The bottom connections of both of the first stage heat exchangers can be tee'd into one head of the pump. The bottom connections of both of the second stage heat exchangers can likewise be joined with a tee to have the water removed by the second head of the pump. The pressure at the bottom of the joined heat exchangers will be equal because of the equal sample flow through each side of the sample cooler. Therefore, each head of the peristaltic pump can service two heat exchangers.

## **START UP PROCEDURE**

Apply power to the sample cooler. The indicated temperature will start to drop immediately. It should be below the over-temperature set points in approximately four minutes and the "COOL" green LED lamps should light. When the temperature reaches the control points (set at 5° C.), the rate at which the temperature drops will be reduced. It will stabilize between 4° and 5° C.

Start the sample gas flow. Water should be observed to be removed from the bottom of each heat exchanger when steady state conditions are established.

If moisture sensors are installed, the (DRY) lights should remain on as dry gas is transported to the analyzer(s).

Turn on the analyzer(s) and calibrate as required.

## **CONTROLLER CIRCUIT BOARD DETAILS**

(Refer to drawing P0024 and schematic E0002)

The controller board takes 15 volts DC from the power supply through silicone insulated, #8 wires to brass studs identified as "DC POWER INPUT". The temperature sensors are type K thermocouples located near the gas outlet locations, one on each side, buried within the cold heat transfer blocks adjacent to the thermoelectrically cooled heat exchangers. An open thermocouple will be indicated. Signal conditioning from the thermocouples includes potentiometer, R60 to match the display to the output of the signal conditioning circuitry; zero and span controls for calibrating the thermocouples, R41 and R37 for Channel 1, and R12 and R3 for Channel 2. The ability to display either degrees C or F is also provided. Adjustments for the control and alarm set points for channel 1 are R29 and R44 respectively; for Channel 2 are R18 and R8 respectively.

Switch "S1" is a two position toggle switch, located on the right hand side of the front panel, which switches the temperature display to indicate either Channel 1 or Channel 2 functions. It is not shown on Drawing P0024 because it is on the back side of the board when observed from that orientation. It is shown on Schematic E0002. When switched to the Channel 1 position, the display indicates the temperature values for Channel 1 dictated by switch "S2" described below. When switched to the Channel 2 position, it indicates the temperature values for Channel 2 as required by "S2".

Switch, "S2" (also not shown on Drawing P0024), is a momentary action toggle switch located on the left hand side of the front panel which allows the display to indicate the temperature of each thermocouple when in the center, relaxed position.

When "S2" is held in the alarm relay set, "RLY" position, the temperature at which the alarm relay will transfer can be adjusted with "R44" (Channel 1) or "R8" (Channel 2). That temperature will be observed on the digital display. The alarm relay is energized below this temperature. The alarm temperature for both channels is set at the factory to 10 degrees C but can be adjusted from 0 to 25 degrees C.

When "S2" is held in the control temperature set, "SET" position, the control temperature is indicated on the display and can be adjusted with "R29" (Channel 1) or "R18" (Channel 2). Control is provided for all Peltier elements through individual power FET's at the bottom of the control circuit board. The 15VDC power to the Peltiers is turned on and off three to five times a second. The duration of the "ON" part of the cycle depends on the temperature. Control is proportional only with a band of 1 degree C. The top of the band temperature is the temperature displayed when "S2" is held in this position. The temperature of both channels is set at the factory to 5 degrees C but is adjustable from 0 to 25 degrees C.

In order to cause the display to indicate in degrees F instead of degrees C as is provided by the factory, the two jumpers at the top of the Control Board should be moved from the marked "C" positions to the marked "F" positions. The offset between the two temperature

scales has been adjusted at the factory using "R64". The gain adjustment between the two temperature scales is set with fixed resistors.

The Peltier elements are individually connected to P1+ through P4+ with flag connectors on red wires. The black wires with flag connectors are attached to P1- through P4- shown on the drawing.

The 2 amp slow blow fuse removes all power from the Control Circuit Board if blown. There will be no lights or indication on the display and the alarm relay will be in the de-energized, alarm position if the fuse is blown.

Connector, "P6" is the connection to both relay boards which contains the circuitry for the Moisture Sensors, and each of the "Cool" and "Dry" relays.

### **CONTROLLER CIRCUIT BOARD DETAILS**

(Refer to drawings P0022, P0004 and schematic E0004.):

Two relay boards, joined together are provided in the dual channel sample coolers. They allow the use of two moisture sensors, one on each channel and provide independent alarms for each channel. The upper section of the relay board is used for Channel 2 and the lower portion is used for Channel 1.

The moisture sensor connections are identified at the top end of each section of the relay board as "PROBE". In order to insure that the moisture sensor will function in a noisy environment, the shield around the active conductor should be connected to terminal #2 on the terminal strip. The jumper which is installed by the factory on the same terminal strip is to allow the moisture circuit to be wired as shown on drawing P0004 through one set of Form "C" contacts from the moisture alarm relay to require a manual reset if moisture is detected. Under normal operation, the moisture relay is energized when the sensor is dry and de-energized when it is wet. The relay will reset itself back into the energized condition when the water is removed from the sensor electrodes.

One set of Form "C" contacts on each moisture sensor relay is protected with MOVs and can be used to interrupt power to a fractional horsepower diaphragm pump (1/10 HP at 120 VAC) used to draw the gas sample through the heat exchangers for each channel.

The temperature alarm relays also have two sets of form "C" contacts brought out to the terminal strips to be used as alarm and annunciator input contacts.

All notations of NC and NO relay contact locations which are screened on the relay circuit board refer to the relay in a de-energized state. The relay is energized in the normal mode and is "fail safe" to relax into the alarm state if power is removed from the circuit board.

## TROUBLE SHOOTING

Tampering and replacement with nonfactory components may adversely affect the safe use of the system.

The presence of water in liquid form after the sample cooler is an indication of a fault in the system. Reasons for the presence of condensate in the system after the sample cooler could be one or more of the following:

1. Overloading of the refrigeration capacity of the cooler due to too much water vapor or too great a sample flow rate.
2. A fault in the condensate removal equipment. The heat exchanger has become full of condensate.
3. An air leak in the condensate removal tubing.
4. The temperature of the air passing through the heat sink is too high due to the cooler being in an enclosed box.
5. Failure of the sample cooler

Dimensional drawings, installation drawings, and schematics are included as part of this manual.

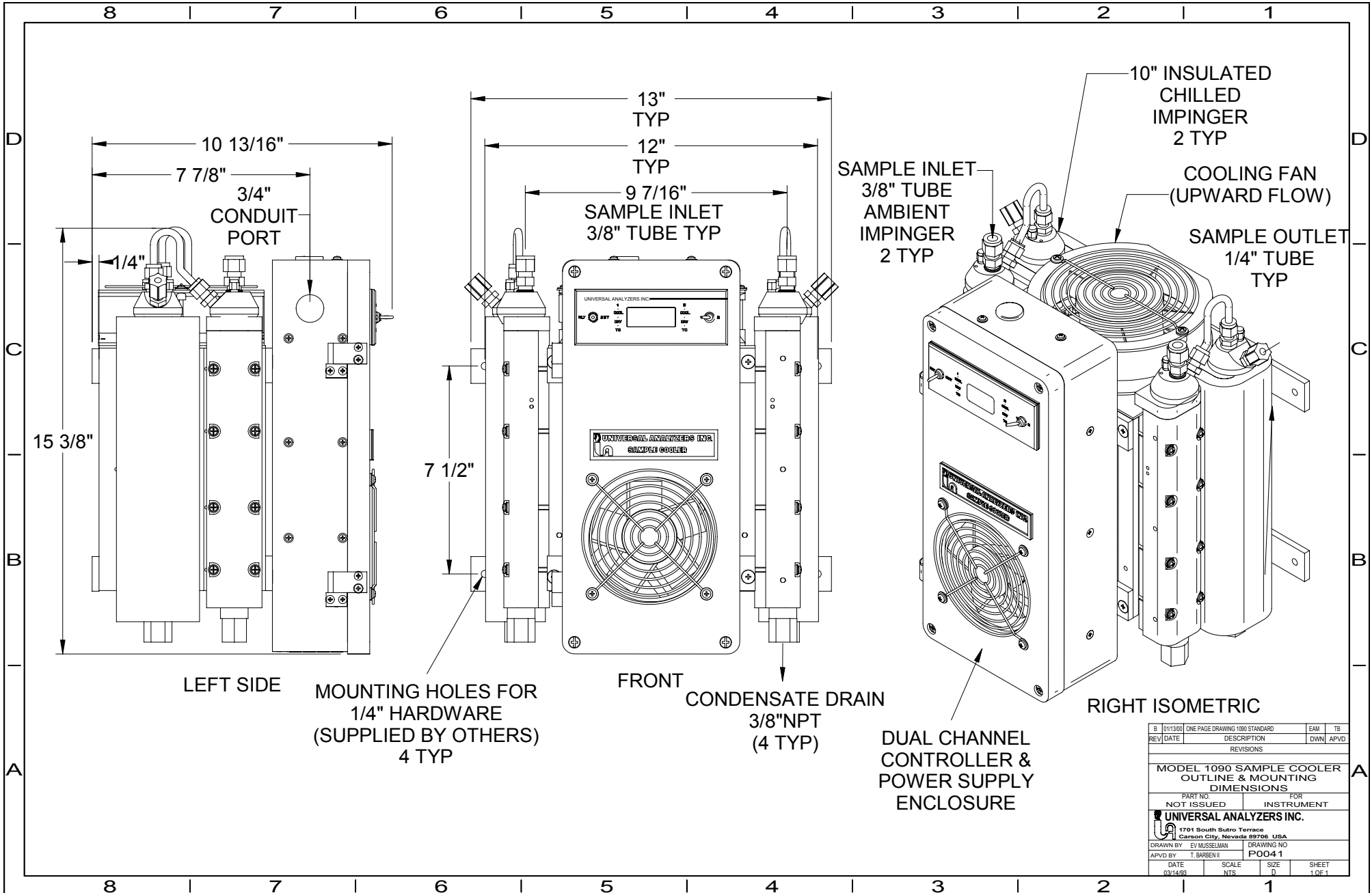

LEFT SIDE MOUNTING HOLES FOR 1/4" HARDWARE (SUPPLIED BY OTHERS) 4 TYP

B	01/13/00	ONE PAGE DRAWING 1090 STANDARD	EAM	TB
REV	DATE	DESCRIPTION	DWN	APVD
REVISIONS				
MODEL 1090 SAMPLE COOLER OUTLINE & MOUNTING DIMENSIONS				
PART NO.		FOR INSTRUMENT		
NOT ISSUED				
UNIVERSAL ANALYZERS INC.				
1701 South Sistrone Terrace Carson City, Nevada 89706 USA				
DRAWN BY EV MUSSELMAN		DRAWING NO P0041		
APVD BY T. BARBENII				
DATE	SCALE	SIZE	SHEET	
03/14/99	NTR	D	1 OF 1	

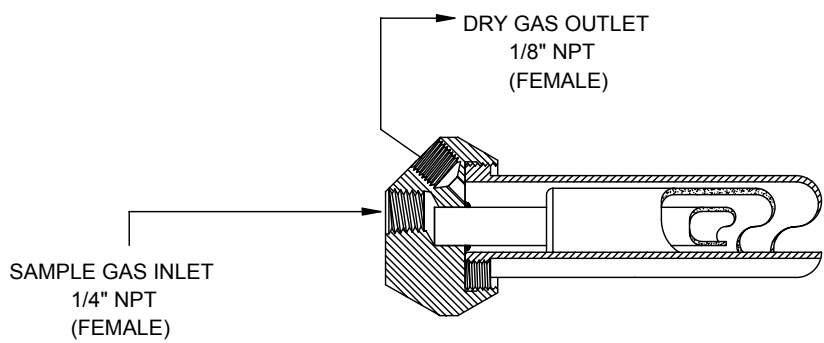
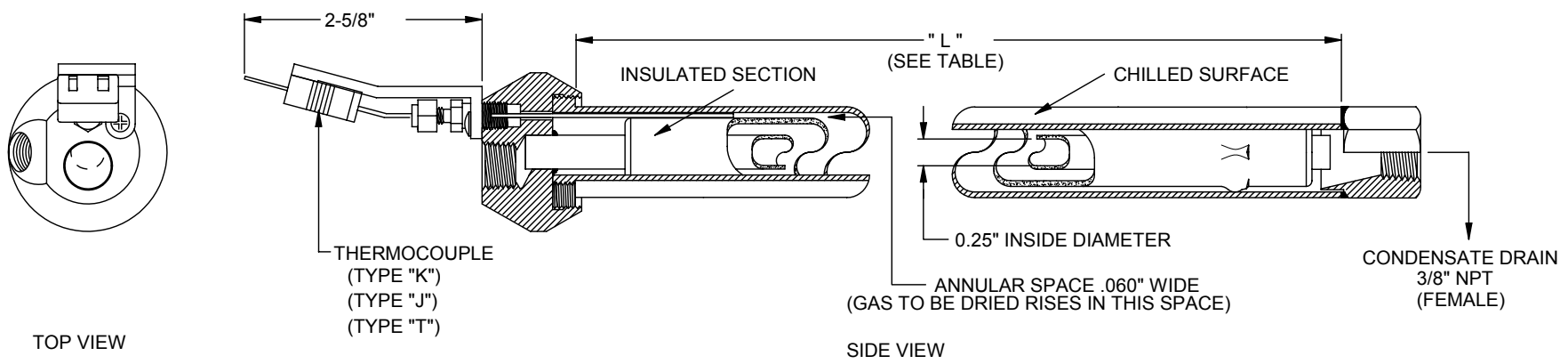
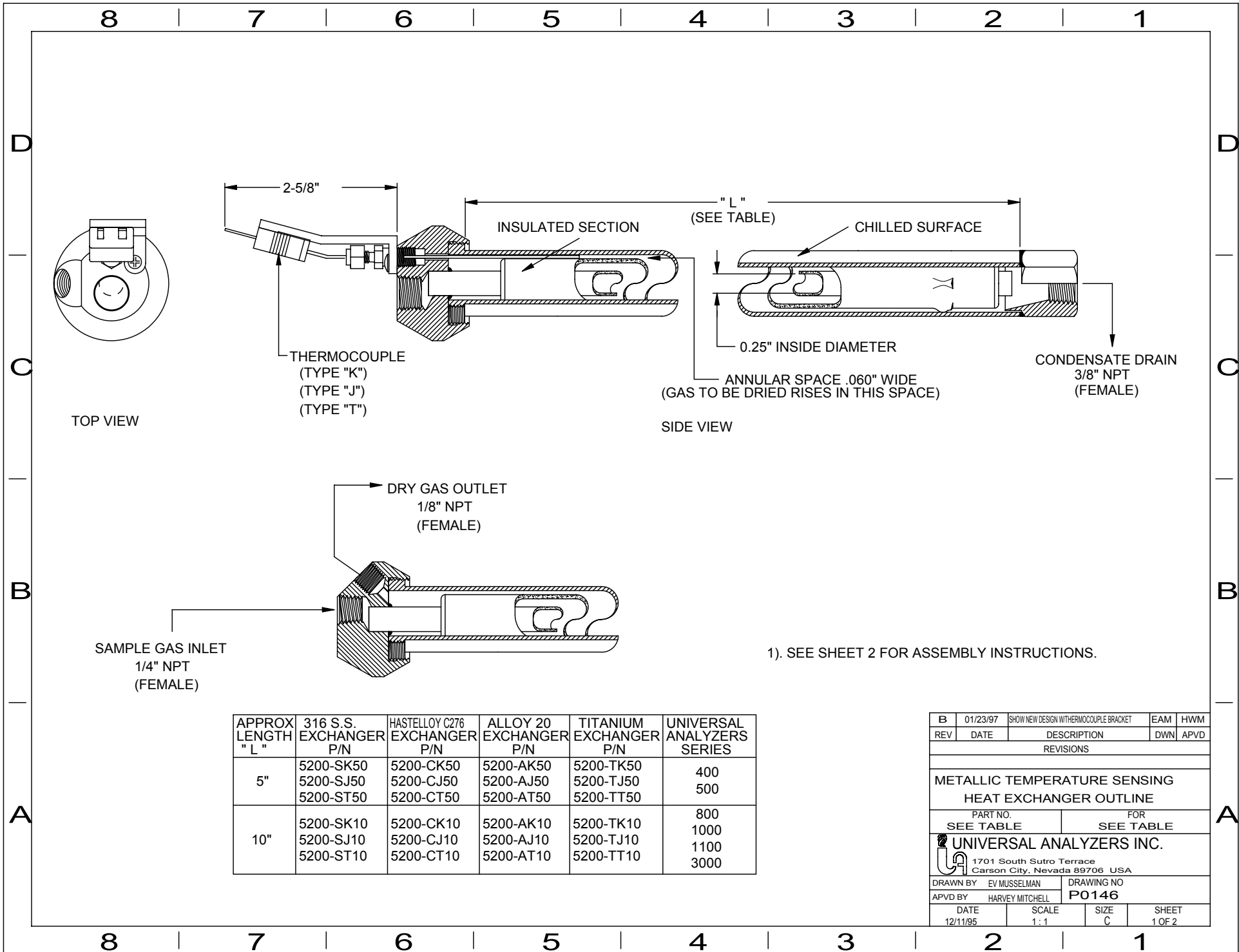

1). SEE SHEET 2 FOR ASSEMBLY INSTRUCTIONS.

APPROX LENGTH "L"	316 S.S. EXCHANGER P/N	HASTELLOY C276 EXCHANGER P/N	ALLOY 20 EXCHANGER P/N	TITANIUM EXCHANGER P/N	UNIVERSAL ANALYZERS SERIES
5"	5200-SK50	5200-CK50	5200-AK50	5200-TK50	400
	5200-SJ50	5200-CJ50	5200-AJ50	5200-TJ50	500
	5200-ST50	5200-CT50	5200-AT50	5200-TT50	
10"	5200-SK10	5200-CK10	5200-AK10	5200-TK10	800
	5200-SJ10	5200-CJ10	5200-AJ10	5200-TJ10	1000
	5200-ST10	5200-CT10	5200-AT10	5200-TT10	1100
					3000

B	01/23/97	SHOW NEW DESIGN WITH THERMOCOUPLE BRACKET	EAM	HWM
REV	DATE	DESCRIPTION	DWN	APVD
REVISIONS				
METALLIC TEMPERATURE SENSING HEAT EXCHANGER OUTLINE				
PART NO. SEE TABLE		FOR SEE TABLE		
UNIVERSAL ANALYZERS INC.				
1701 South Sutro Terrace Carson City, Nevada 89706 USA				
DRAWN BY EV MUSSELMAN		DRAWING NO P0146		
APVD BY HARVEY MITCHELL				
DATE 12/11/95	SCALE 1:1	SIZE C	SHEET 1 OF 2	

8 | 7 | 6 | 5 | 4 | 3 | 2 | 1

### EXPLODED METALLIC HEAT EXCHANGER

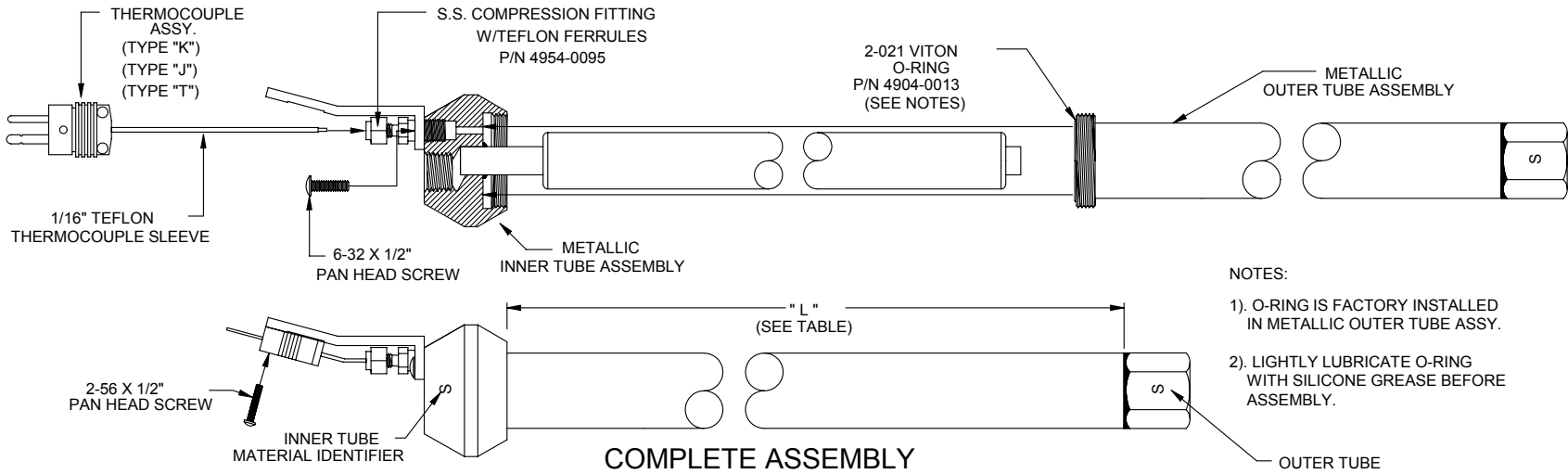

**NOTES:**

- 1). O-RING IS FACTORY INSTALLED IN METALLIC OUTER TUBE ASSY.
- 2). LIGHTLY LUBRICATE O-RING WITH SILICONE GREASE BEFORE ASSEMBLY.

### COMPLETE ASSEMBLY

**SPARE PARTS LIST**

"L" LENGTH	MATERIAL DESC.	COMPLETE ASSY P/N	OUTER TUBE ASSY P/N	INNER TUBE ASSY P/N	TYPE "K" THERMOCOUPLE ASSEMBLY P/N	TYPE "J" THERMOCOUPLE ASSEMBLY P/N	TYPE "T" THERMOCOUPLE ASSEMBLY P/N
5"	316 S.S.	5200-SK50	5201-0012	5201-0015	1150-0011	X	X
5"	"	5200-SJ50	"	"	X	1150-0012	X
5"	"	5200-ST50	"	"	X	X	1150-0013
5"	ALLOY 20	5200-AK50	5201-0022	"	"	X	X
5"	"	5200-AJ50	"	"	X	"	X
5"	"	5200-AT50	"	"	X	X	"
5"	HASTELLOY C276	5200-CK50	5201-0020	"	"	X	X
5"	"	5200-CJ50	"	"	X	"	X
5"	"	5200-CT50	"	"	X	X	"
5"	TITANIUM	5200-TK50	5201-0024	5201-0028	1150-0018	X	X
5"	"	5200-TJ50	"	"	X	1150-0019	X
5"	"	5200-TT50	"	"	X	X	1150-0014
10"	316 S.S.	5200-SK10	5201-0013	5201-0016	1150-0011	X	X
10"	"	5200-SJ10	"	"	X	1150-0012	X
10"	"	5200-ST10	"	"	X	X	1150-0013
10"	ALLOY 20	5200-AK10	5201-0023	"	"	X	X
10"	"	5200-AJ10	"	"	X	"	X
10"	"	5200-AT10	"	"	X	X	"
10"	HASTELLOY C276	5200-CK10	5201-0021	"	"	X	X
10"	"	5200-CJ10	"	"	X	"	X
10"	"	5200-CT10	"	"	X	X	"
10"	TITANIUM	5200-TK10	5201-0025	5201-0029	1150-0018	X	X
10"	"	5200-TJ10	"	"	X	1150-0019	X
10"	"	5200-TT10	"	"	X	X	1150-0014

B	01/23/97	SHOW NEW DESIGN WITH THERMOCOUPLE BRACKET	EAM	HWM
REV	DATE	DESCRIPTION	DWN	APVD
REVISIONS				
<b>METALLIC TEMPERATURE SENSING HEAT EXCHANGER ASSEMBLY</b>				
PART NO. <b>SEE TABLE</b>		FOR 400 500 800 1000 1100 3000 SERIES		
<b>UNIVERSAL ANALYZERS INC.</b>				
1701 South Sutro Terrace Carson City, Nevada 89706 USA				
DRAWN BY EV MUSSELMAN		DRAWING NO <b>P0146</b>		
APVD BY HARVEY MITCHELL		DATE 12/11/95	SCALE 1:1	SHEET 2 OF 2

8 | 7 | 6 | 5 | 4 | 3 | 2 | 1

8 | 7 | 6 | 5 | 4 | 3 | 2 | 1

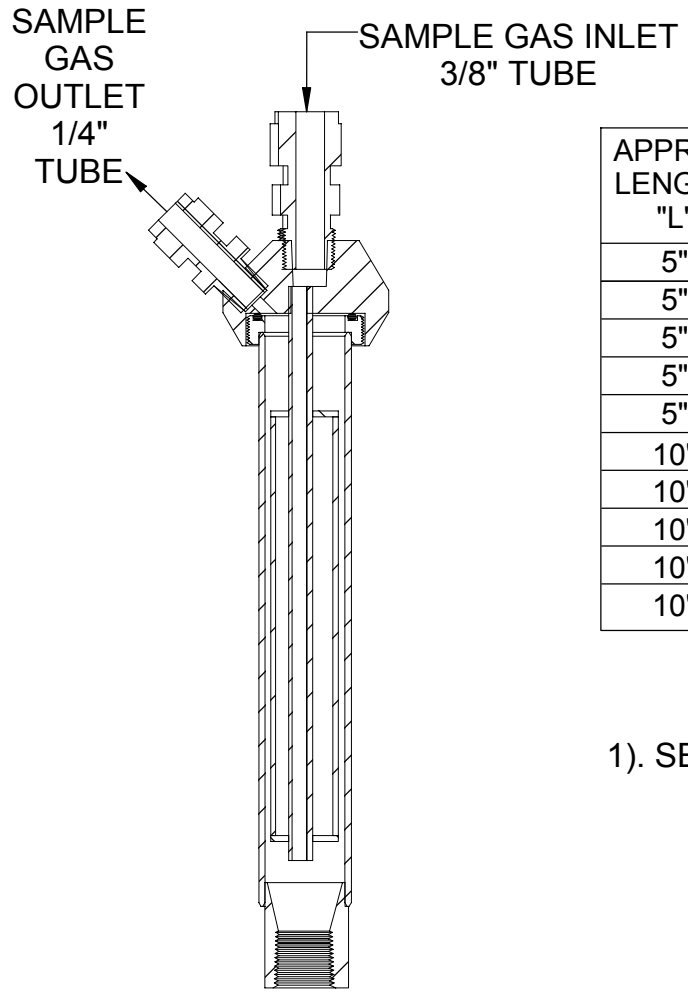
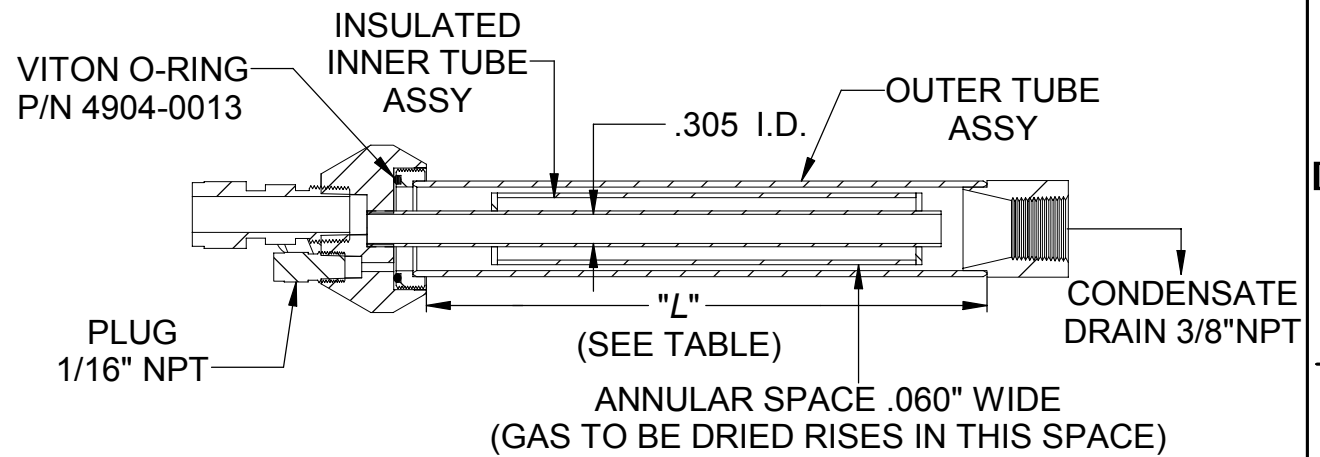
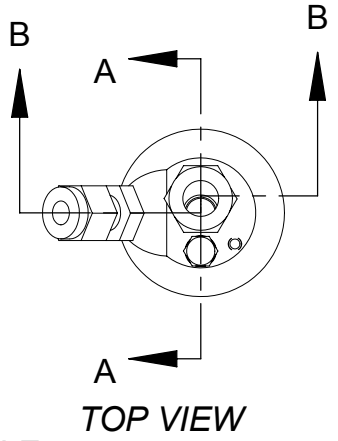

APPROX LENGTH "L"	HEAT EXCHANGER P/N	OUTER TUBE MATERIAL	UNIVERSAL ANALYZERS SERIES
5"	5200-S050	316 S.S.	400/500
5"	5200-T050	TITANIUM	400/500
5"	5200-A050	ALLOY 20	400/500
5"	5200-C050	HASTELLOY C-276	400/500
5"	5200-S05T	TEFLON COATED 316 S.S.	400/500
10"	5200-S010	316 S.S.	800/1000/1100/3000
10"	5200-T010	TITANIUM	800/1000/1100/3000
10"	5200-A010	ALLOY 20	800/1000/1100/3000
10"	5200-C010	HASTELLOY C-276	800/1000/1100/3000
10"	5200-S01T	TEFLON COATED 316 S.S.	800/1000/1100/3000

1). SEE SHEET 2 FOR ASSEMBLY INSTRUCTIONS.

A	02/09/99	REVISE P/N TABLE FOR TEFLON COATED	EAM	RD
REV	DATE	DESCRIPTION	DWN	APVD
REVISIONS				
<b>HEAT EXCHANGER METALLIC NON-TEMPERATURE SENSING OUTLINE</b>				
PART NO. SEE TABLE		FOR SEE TABLE		
<b>UNIVERSAL ANALYZERS INC.</b>				
1701 South Sutro Terrace Carson City, Nevada 89706 USA				
DRAWN BY EV MUSSELMAN		DRAWING NO <b>P0147</b>		
APVD BY H. MITCHELL				
DATE 12/11/95	SCALE NONE	SIZE C	SHEET 1 OF 2	

8 | 7 | 6 | 5 | 4 | 3 | 2 | 1

8 | 7 | 6 | 5 | 4 | 3 | 2 | 1

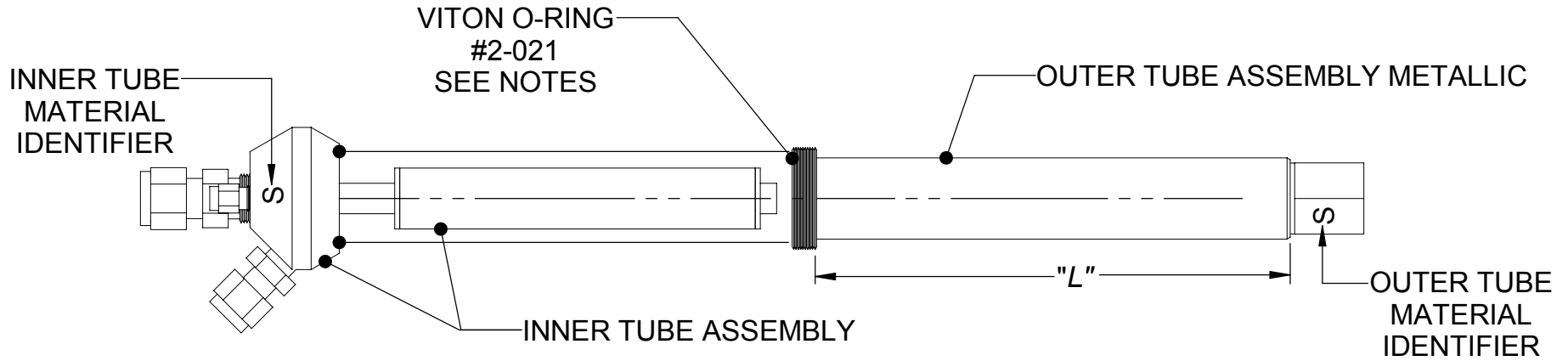

HEAT EXCHANGER SEPERABLE		SPARE PARTS LIST			
APPROX "L" LENGTH	P/N	INNER TUBE ASSY P/N	OUTER TUBE ASSY P/N	VITON O-RING #2-021 P/N	PLUG 1/16"NPT P/N
5"	5200-S050	5201-0015	5201-0012	4904-0013	4951-0058
5"	5200-T050	"	5201-0024	"	"
5"	5200-A050	"	5201-0022	"	"
5"	5200-C050	"	5201-0020	"	"
5"	5200-S05T	5201-0041	5201-0043	"	"
10"	5200-S010	5201-0016	5201-0013	4904-0013	4951-0058
10"	5200-T010	"	5201-0025	"	"
10"	5200-A010	"	5201-0023	"	"
10"	5200-C010	"	5201-0021	"	"
10"	5200-S01T	5201-0042	5201-0044	"	"

NOTES:  
 1). O-RING IS FACTORY INSTALLED IN METALLIC OUTER TUBE.  
 2). LIGHTLY LUBRICATE O-RING WITH SILICONE GREASE BEFORE ASSEMBLY.

A	02/09/99	REVISE TABLE TO INCLUDE TEFLON PARTS	EAM	RD
REV	DATE	DESCRIPTION	DWN	APVD
REVISIONS				
HEAT EXCHANGER ASSEMBLY NON-TEMPERATURE SENSING METALLIC				
PART NO. SEE TABLE		FOR INSTRUMENT		
<b>UNIVERSAL ANALYZERS INC.</b>				
1701 South Sutro Terrace Carson City, Nevada 89706 USA				
DRAWN BY EV MUSSELMAN		DRAWING NO		
APVD BY H. MITCHELL		P0147		
DATE 12/11/95		SCALE NONE	SIZE C	SHEET 2 OF 2

8 | 7 | 6 | 5 | 4 | 3 | 2 | 1

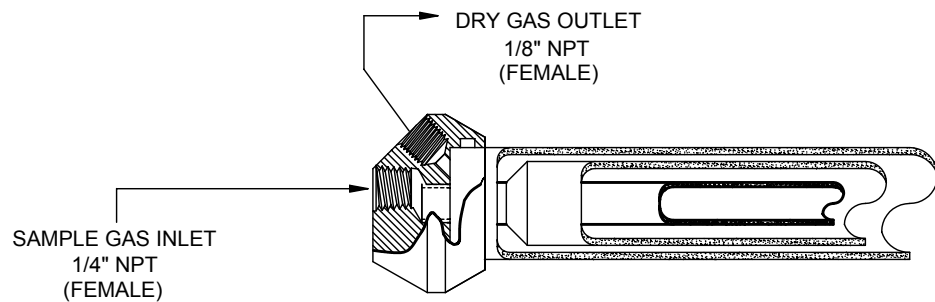
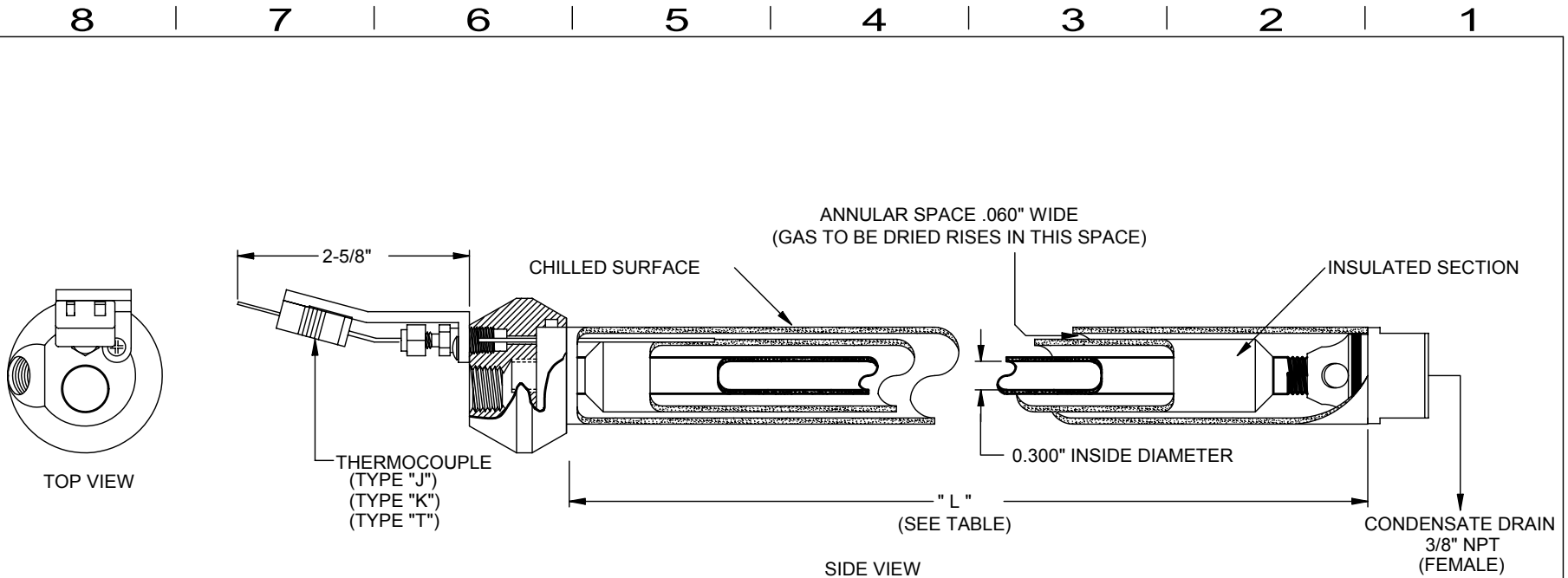

1). SEE SHEET 2 FOR ASSEMBLY INSTRUCTIONS.

LENGTH "L"	GLASS KYNAR HEAT EXCHANGER ASSEMBLY P/N	UNIVERSAL ANALYZERS SAMPLE COOLER MODELS
5"	5200-KK50	520
	5200-KJ50	530
	5200-KT50	540
		570
10"		1040
	5200-KK10	1050
	5200-KJ10	1060
	5200-KT10	1080
		1090
15"	5200-KK15	FGA2
	5200-KJ15	
	5200-KT15	

C	10/02/01	Add 15" Heat Exchanger Data To Table	EM	JK
REV	DATE	DESCRIPTION	DWN	APVD
REVISIONS				
<b>Glass Kynar Temperature Sensing Heat Exchanger Outline</b>				
PART NO. SEE TABLE		FOR SEE TABLE		
<b>UNIVERSAL ANALYZERS INC.</b>				
1701 South Sutro Terrace Carson City, Nevada 89706 USA				
DRAWN BY E. Mussleman		DRAWING NO P0148		
APVD BY H. Mitchell				
DATE	SCALE	SIZE	SHEET	
12/11/95	1:1	C	1 OF 2	

8

7

6

5

4

3

2

1

### EXPLODED GLASS KYNAR HEAT EXCHANGER

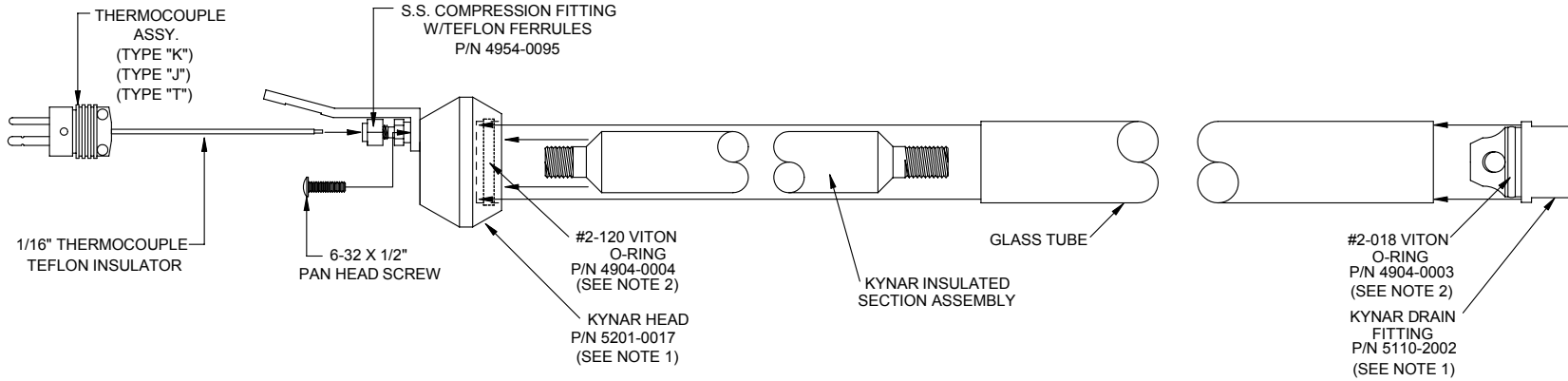

SPARE PARTS LIST						
GLASS KYNAR HEAT EXCHANGER ASSEMBLY		KYNAR INSULATED SECTION ASSEMBLY	GLASS TUBE	TYPE "K" THERMOCOUPLE	TYPE "J" THERMOCOUPLE	TYPE "T" THERMOCOUPLE
LENGTH "L"	P/N	P/N	P/N	P/N	P/N	P/N
5"	5200-KK50	5110-2003	5201-0002	1150-0011	1150-0012	1150-0013
5"	5200-KJ50	"	"	"	"	"
5"	5200-KT50	"	"	"	"	"
10"	5200-KK10	5110-2004	5201-0001	"	"	"
10"	5200-KJ10	"	"	"	"	"
10"	5200-KT10	"	"	"	"	"
15"	5200-KK15	5110-2006	5201-0078	"	"	"
15"	5200-KJ15	"	"	"	"	"
15"	5200-KT15	"	"	"	"	"

NOTES:

- O-RINGS ARE FACTORY INSTALLED IN KYNAR HEAD AND KYNAR DRAIN FITTING.
- LIGHTLY LUBRICATE O-RINGS WITH SILICONE GREASE BEFORE ASSEMBLY.

C	10/02/01	Add 15" Data To Parts List Table	EM	JK
REV	DATE	DESCRIPTION	DWN	APVD
REVISIONS				
Glass Kynar Temperature Sensing Heat Exchanger Spare Parts List Exploded Assembly				
PART NO. SEE TABLE		FOR SAMPLE COOLERS		
<b>UNIVERSAL ANALYZERS INC.</b>				
1701 South Sutro Terrace Carson City, Nevada 89706 USA				
DRAWN BY E. Musselman		DRAWING NO P0148		
APVD BY H. Mitchell		DATE 12/11/95	SCALE 1 : 1	SHEET 2 OF 2

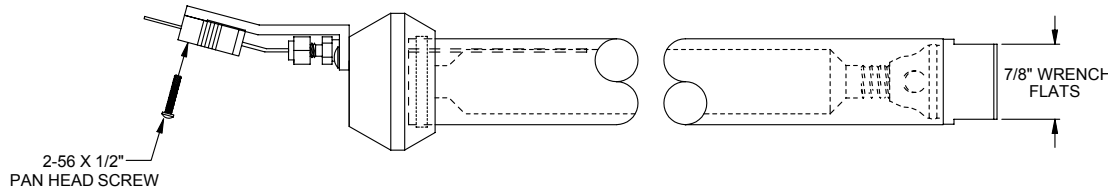

### COMPLETE GLASS KYNAR HEAT EXCHANGER ASSEMBLY

8

7

6

5

4

3

2

1

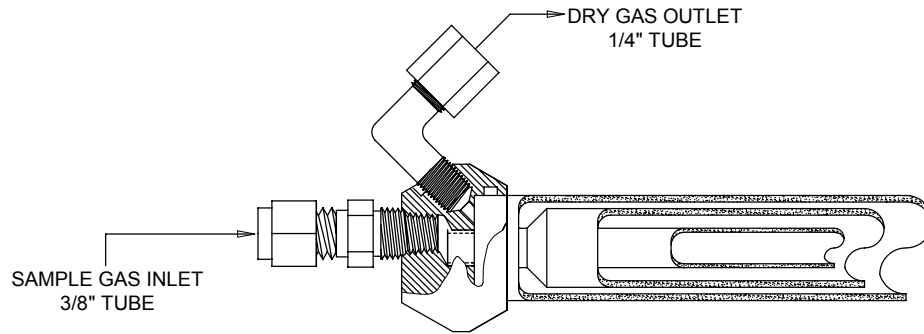
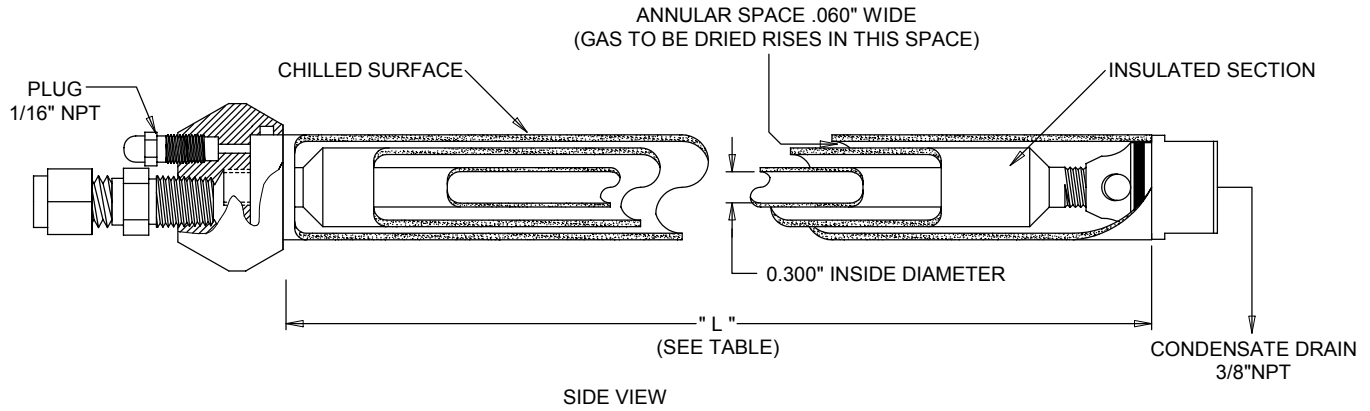
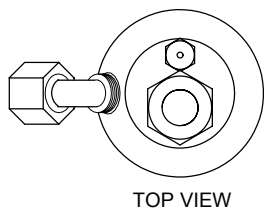

1). SEE SHEET 2 FOR ASSEMBLY INSTRUCTIONS.

LENGTH "L"	GLASS KYNAR HEAT EXCHANGER ASSEMBLY P/N	UNIVERSAL ANALYZERS SAMPLE COOLER MODELS	QTY OF EXCHANGERS PER SAMPLE COOLER
5"	5200-K050	520	1
		530	2
		540	2
		570	4
10"	5200-K010	1040	1
		1050	2
		1060	2
		1080	2
		1090	4
15"	5200-K015	FGA2	1

B	10/02/01	Add 15" Data To Table	EM	RD
REV	DATE	DESCRIPTION	DWN	APVD
REVISIONS				
<b>HEAT EXCHANGER GLASS / KYNAR NON-TEMPERATURE SENSING OUTLINE</b>				
PART NO. SEE TABLE		FOR INSTRUMENT		
<b>UNIVERSAL ANALYZERS INC.</b>				
1701 South Sutro Terrace Carson City, Nevada 89706 USA				
DRAWN BY EV MUSSELMAN		DRAWING NO P0149		
APVD BY H. MITCHELL				
DATE 12/11/95	SCALE 1:1	SIZE C	SHEET 1 OF 2	

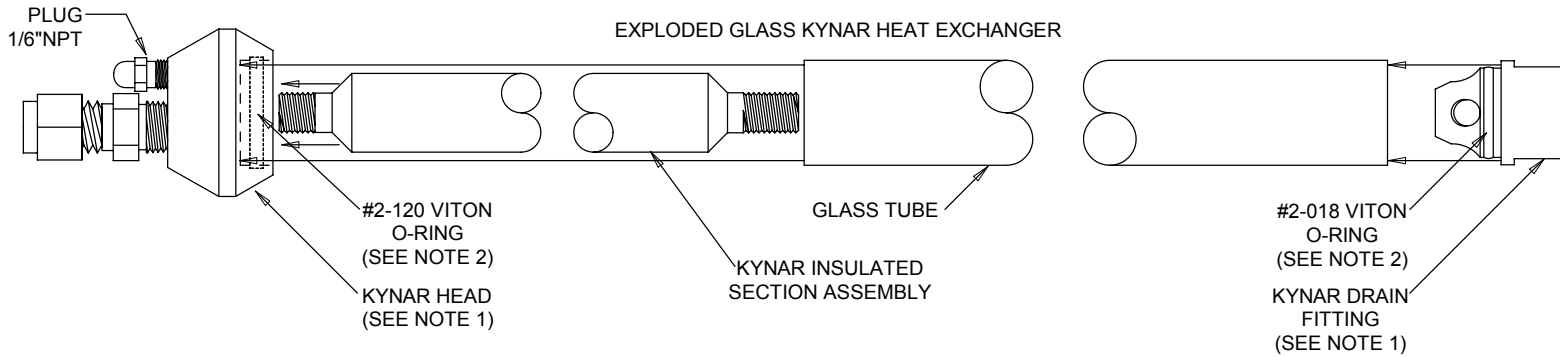

SPARE PARTS LIST								
GLASS KYNAR HEAT EXCHANGER ASSEMBLY		KYNAR INSULATED SECTION ASSY	GLASS TUBE	KYNAR DRAIN FITTING	#2-120 VITON O-RING	#2-018 VITON O-RING	KYNAR HEAD	1/16\" NPT PLUG
LENGTH \"L\"	P/N	P/N	P/N	P/N	P/N	P/N	P/N	P/N
5"	5200-K050	5110-2003	5201-0002	5110-2002	4904-0004	4904-0003	5201-0017	4951-0066
10"	5200-K010	5110-2004	5201-0001	"	"	"	"	"
15"	5200-K015	5110-2006	5201-0078	"	"	"	"	"

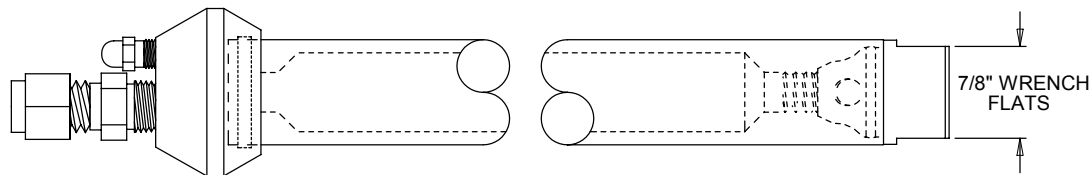

COMPLETE GLASS KYNAR HEAT EXCHANGER ASSEMBLY

NOTES:

- O-RINGS ARE FACTORY INSTALLED IN KYNAR HEAD AND KYNAR DRAIN FITTINGS
- LIGHTLY LUBRICATE O-RINGS WITH SILICONE GREASE BEFORE ASSEMBLY.

B	10/02/01	Add 15" Data to Table	EAM	RD
REV	DATE	DESCRIPTION	DWN	APVD
REVISIONS				
<b>HEAT EXCHANGER GLASS / KYNAR NON-TEMPERATURE SENSING SPARE PART INSTALLATION</b>				
PART NO. SEE TABLE		FOR INSTRUMENT		
<b>UNIVERSAL ANALYZERS INC.</b>				
1701 South Sutro Terrace Carson City, Nevada 89706 USA				
DRAWN BY EV MUSSELMAN		DRAWING NO P0149		
APVD BY H. MITCHELL				
DATE 12/11/95	SCALE 1:1	SIZE C	SHEET 2 OF 2	

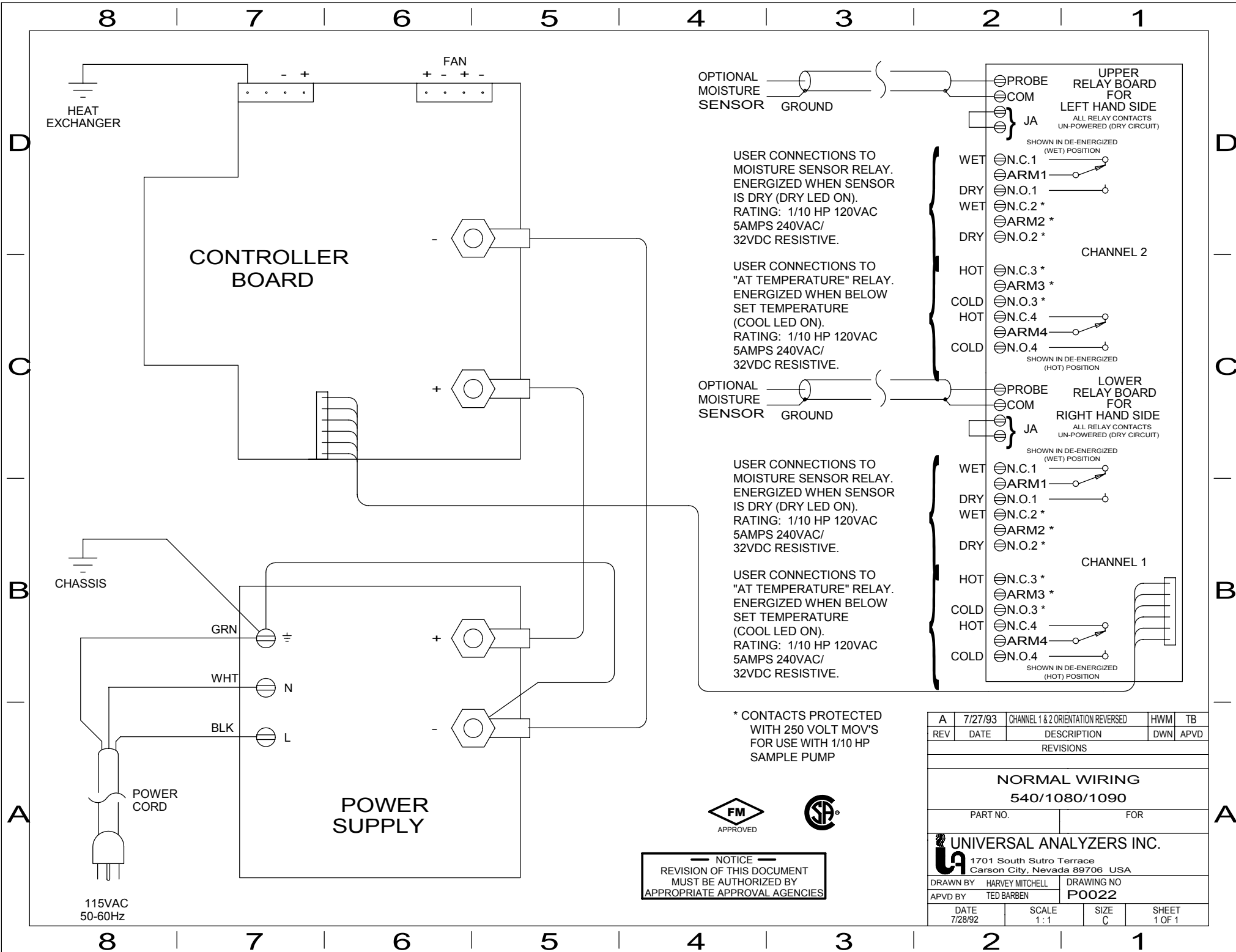

A	7/27/93	CHANNEL 1 & 2 ORIENTATION REVERSED	HWM	TB
REV	DATE	DESCRIPTION	DWN	APVD
REVISIONS				
<b>NORMAL WIRING</b>				
<b>540/1080/1090</b>				
PART NO.		FOR		
<b>UNIVERSAL ANALYZERS INC.</b>				
1701 South Sutro Terrace Carson City, Nevada 89706 USA				
DRAWN BY HARVEY MITCHELL		DRAWING NO		
APVD BY TED BARBEN		<b>P0022</b>		
DATE	SCALE	SIZE	SHEET	
7/28/92	1:1	C	1 OF 1	

8 | 7 | 6 | 5 | 4 | 3 | 2 | 1

D

D

C

C

B

B

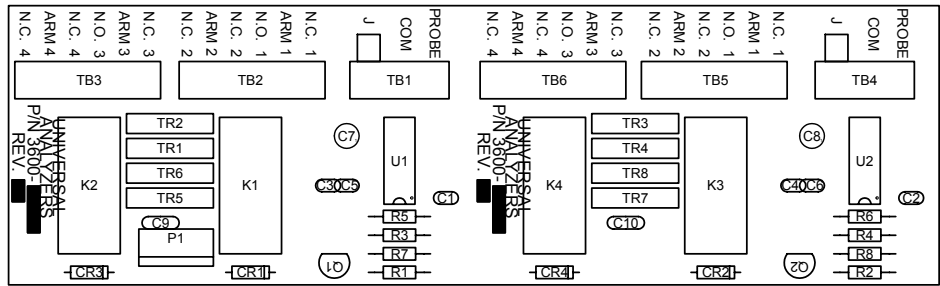

DIMENSIONS IN INCHES.

A

A

ITEM	REQ'D	DWG NO.	DWG SIZE	PART NO.	NAME
					SCHEMATIC E0004 E0060
				3600-0007 / 0030	NAME PARTS LOCATION
					FOR DUAL CHANNEL RELAY
				SCALE FULL	DATE 8/17/95
					INTERNATIONAL
					<b>UNIVERSAL ANALYZERS INC.</b>
				SIZE B	DRAWING NO. E0006
				REV. B	DWN. MRM
					CHKD TB
					APVD TB
					ENGR. TB
				SHEET	CONT. ON.

THIRD ANGLE PROJECTIONS

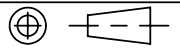

ASSY OR B/M  
3600-0013

SUPERSEDES  
DWG.  
UNLESS OTHERWISE INDICATED:  
ANGLES = ± 2°  
MACHINED FINISH 300/0R BETTER  
CHAMFER ANGLE = ± 3°  
CHAMFER LENGTH = ± .015"  
DIMENSIONS ENCLOSED IN A   
ARE MORE CRITICAL THAN APPLICABLE  
INDUSTRY STANDARDS.  
ALL DIMENSIONS ± .005" UNLESS  
OTHERWISE SPECIFIED.

Package To Prevent Handling  
And Stacking Damage

FINISH \_\_\_\_\_  
PER SPEC. \_\_\_\_\_

8 | 7 | 6 | 5 | 4 | 3 | 2 | 1

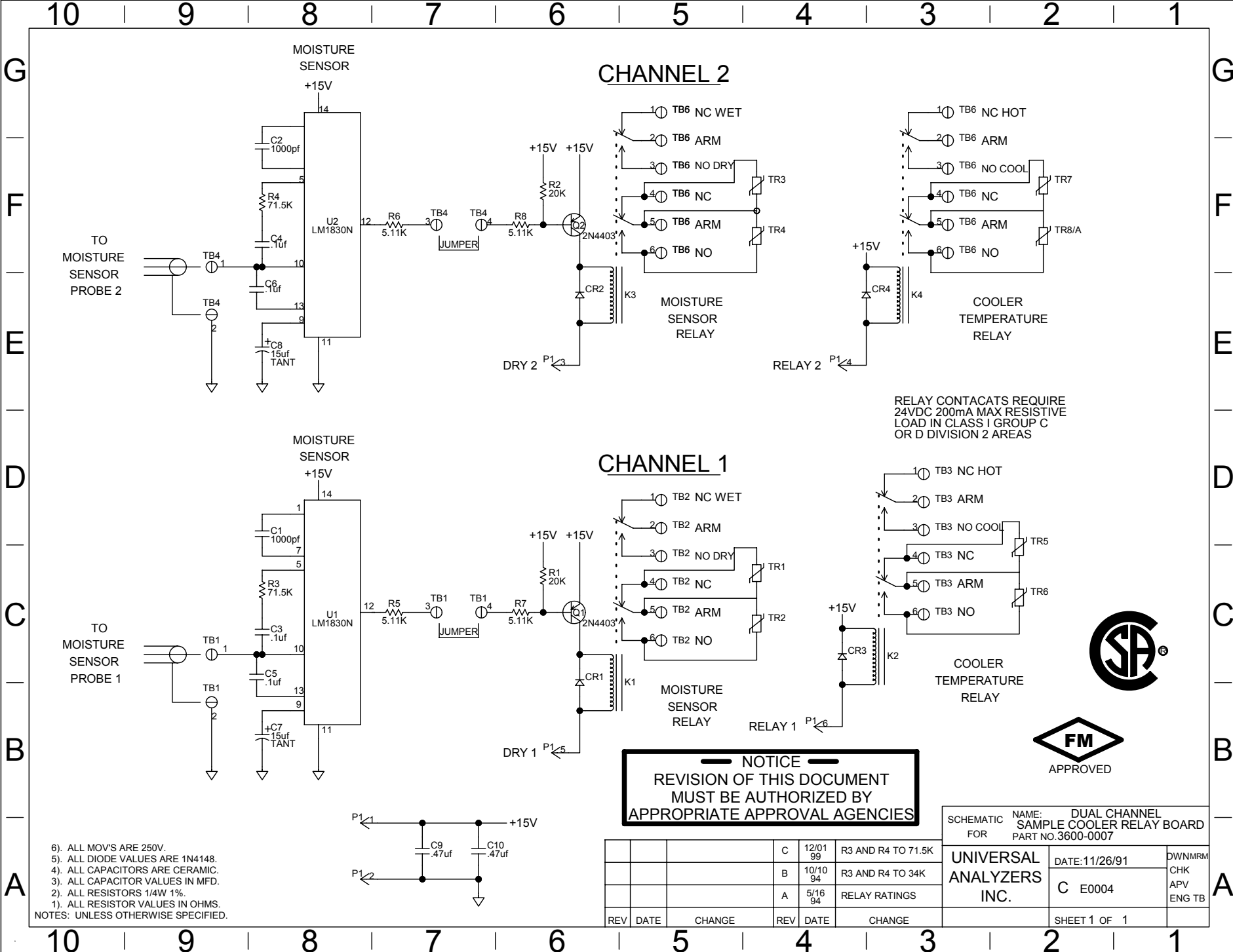

**CHANNEL 2**

**CHANNEL 1**

RELAY CONTACTS REQUIRE  
24VDC 200mA MAX RESISTIVE  
LOAD IN CLASS I GROUP C  
OR D DIVISION 2 AREAS

**NOTICE**  
REVISION OF THIS DOCUMENT  
MUST BE AUTHORIZED BY  
APPROPRIATE APPROVAL AGENCIES



SCHEMATIC NAME: DUAL CHANNEL  
FOR SAMPLE COOLER RELAY BOARD  
PART NO.3600-0007

UNIVERSAL ANALYZERS INC.	DATE: 11/26/91	DWNMRM
	C E0004	CHK APV ENG TB
SHEET 1 OF 1		

REV	DATE	CHANGE	REV	DATE	CHANGE
C	12/01/99	R3 AND R4 TO 71.5K			
B	10/10/94	R3 AND R4 TO 34K			
A	5/16/94	RELAY RATINGS			

- 6). ALL MOV'S ARE 250V.
  - 5). ALL DIODE VALUES ARE 1N4148.
  - 4). ALL CAPACITORS ARE CERAMIC.
  - 3). ALL CAPACITOR VALUES IN MFD.
  - 2). ALL RESISTORS 1/4W 1%.
  - 1). ALL RESISTOR VALUES IN OHMS.
- NOTES: UNLESS OTHERWISE SPECIFIED.

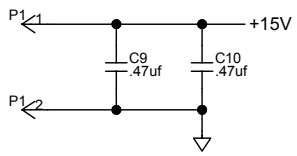



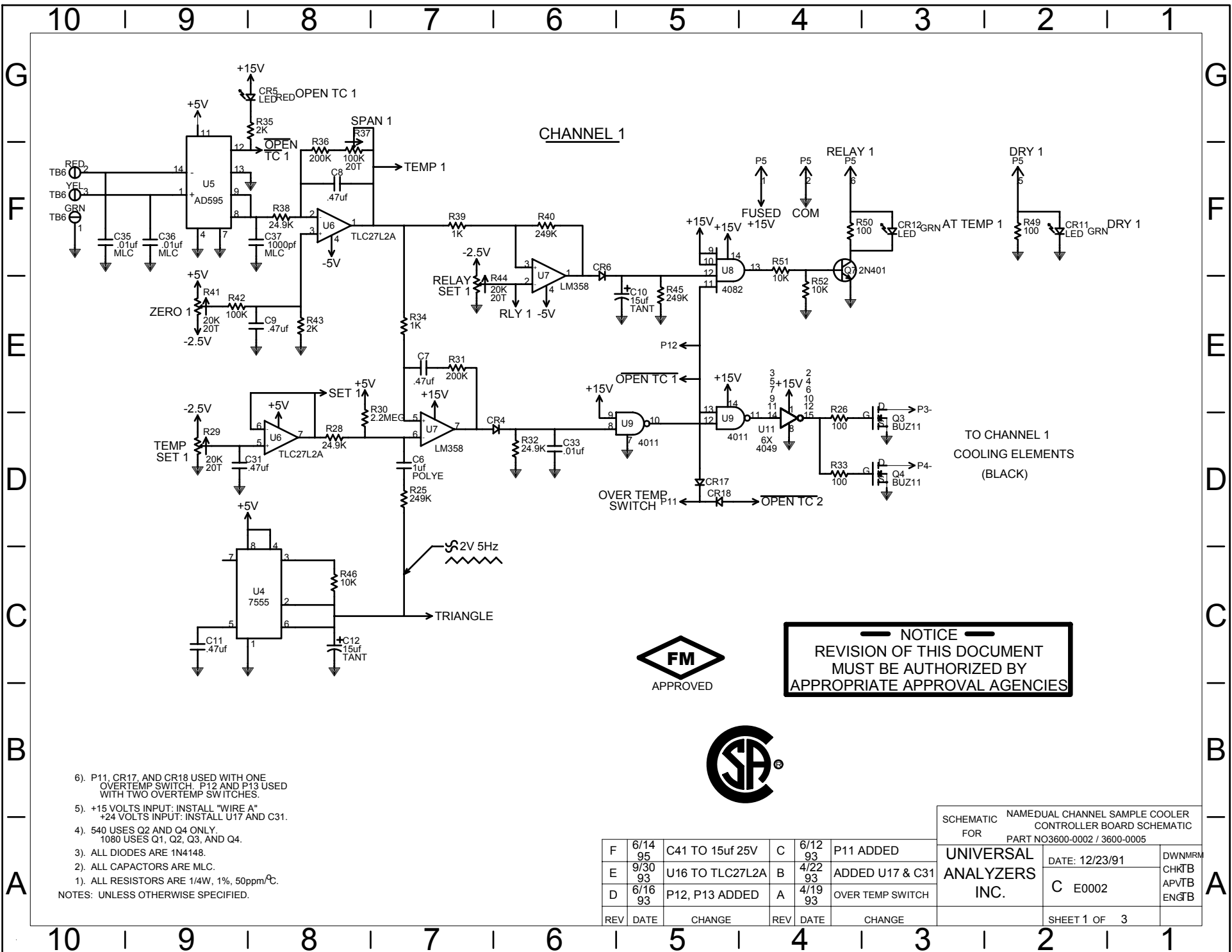

TO CHANNEL 1  
COOLING ELEMENTS  
(BLACK)

**NOTICE**  
REVISION OF THIS DOCUMENT  
MUST BE AUTHORIZED BY  
APPROPRIATE APPROVAL AGENCIES



- 6). P11, CR17, AND CR18 USED WITH ONE OVERTEMP SWITCH. P12 AND P13 USED WITH TWO OVERTEMP SWITCHES.
  - 5). +15 VOLTS INPUT: INSTALL "WIRE A" +24 VOLTS INPUT: INSTALL U17 AND C31.
  - 4). 540 USES Q2 AND Q4 ONLY. 1080 USES Q1, Q2, Q3, AND Q4.
  - 3). ALL DIODES ARE 1N4148.
  - 2). ALL CAPACITORS ARE MLC.
  - 1). ALL RESISTORS ARE 1/4W, 1%, 50ppm/C.
- NOTES: UNLESS OTHERWISE SPECIFIED.

F		6/14/95	C41 TO 15uf 25V	C	6/12/93	P11 ADDED	SCHEMATIC FOR <b>UNIVERSAL ANALYZERS INC.</b> NAMEDUAL CHANNEL SAMPLE COOLER CONTROLLER BOARD SCHEMATIC PART NO3600-0002 / 3600-0005 DATE: 12/23/91 C E0002 SHEET 1 OF 3	DWNMRM CHKTB APVTB ENGB
E		9/30/93	U16 TO TLC27L2A	B	4/22/93	ADDED U17 & C31		
D		6/16/93	P12, P13 ADDED	A	4/19/93	OVER TEMP SWITCH		
REV		DATE	CHANGE	REV		DATE		

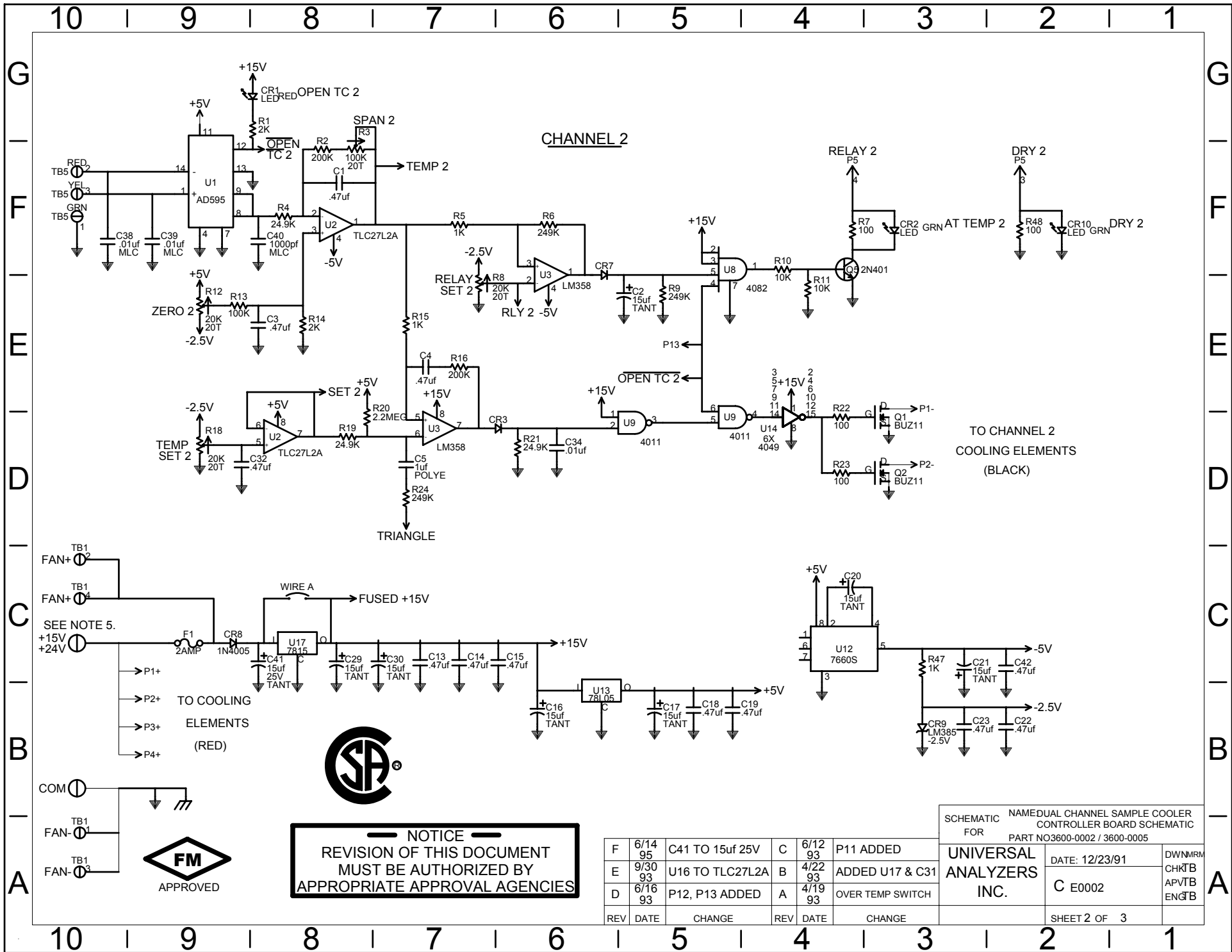

**NOTICE**  
 REVISION OF THIS DOCUMENT  
 MUST BE AUTHORIZED BY  
 APPROPRIATE APPROVAL AGENCIES

REV	DATE	CHANGE	REV	DATE	CHANGE
F	6/14/95	C41 TO 15uf 25V	C	6/12/93	P11 ADDED
E	9/30/93	U16 TO TLC27L2A	B	4/22/93	ADDED U17 & C31
D	6/16/93	P12, P13 ADDED	A	4/19/93	OVER TEMP SWITCH

SCHEMATIC FOR		NAME DUAL CHANNEL SAMPLE COOLER CONTROLLER BOARD SCHEMATIC	
		PART NO 3600-0002 / 3600-0005	
<b>UNIVERSAL ANALYZERS INC.</b>	DATE:	12/23/91	
		C E0002	
		SHEET 2 OF 3	

DWNMRM  
 CHKTB  
 APVTB  
 ENGB

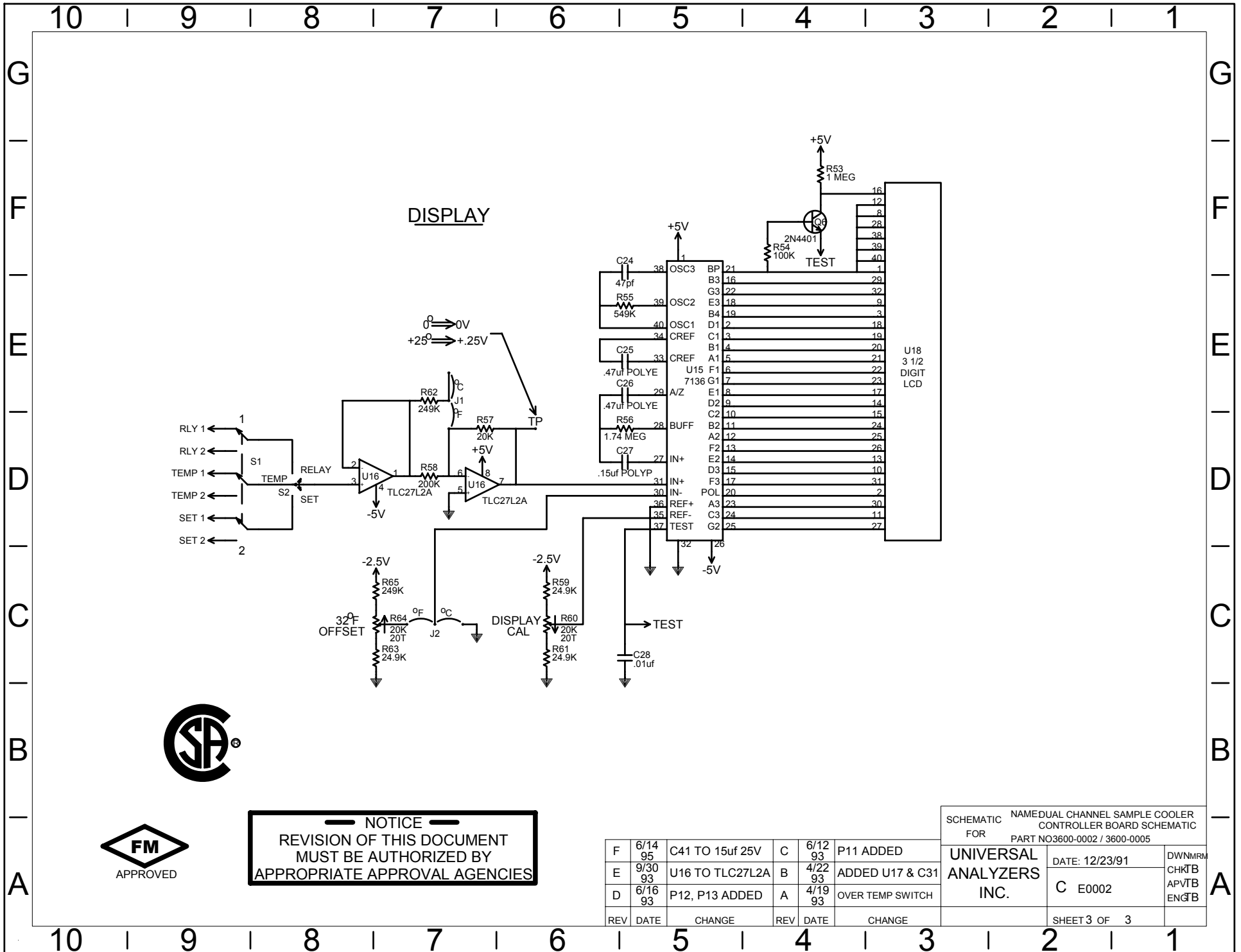



**NOTICE**  
 REVISION OF THIS DOCUMENT  
 MUST BE AUTHORIZED BY  
 APPROPRIATE APPROVAL AGENCIES

REV	DATE	CHANGE	REV	DATE	CHANGE
F	6/14/95	C41 TO 15uf 25V	C	6/12/93	P11 ADDED
E	9/30/93	U16 TO TLC27L2A	B	4/22/93	ADDED U17 & C31
D	6/16/93	P12, P13 ADDED	A	4/19/93	OVER TEMP SWITCH

SCHEMATIC FOR NAMEDUAL CHANNEL SAMPLE COOLER CONTROLLER BOARD SCHEMATIC PART NO3600-0002 / 3600-0005	
<b>UNIVERSAL ANALYZERS INC.</b>	DATE: 12/23/91
	C E0002
	SHEET 3 OF 3

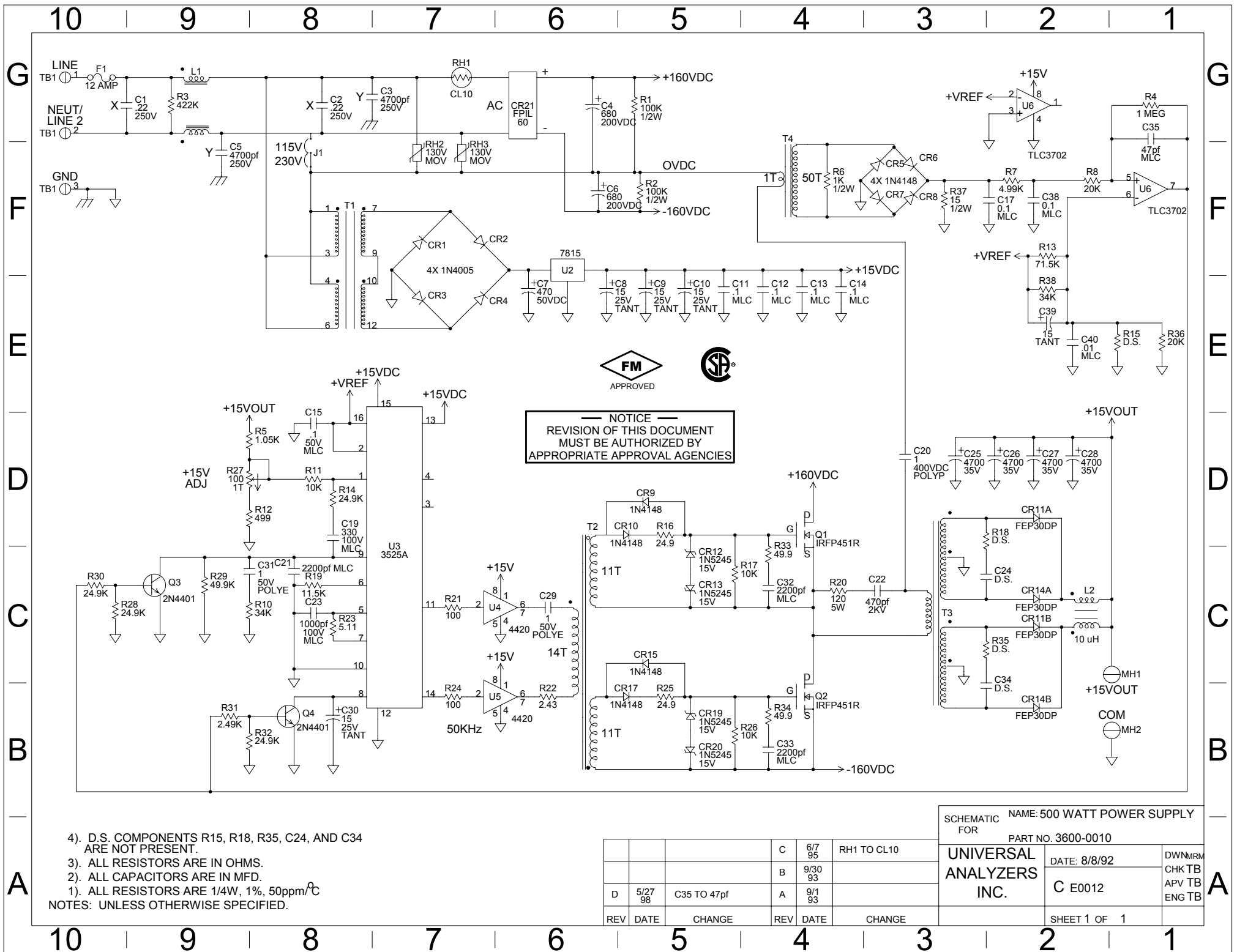
DWNMRM  
 CHKTB  
 APVTB  
 ENGTB





  
**NOTICE**  
 REVISION OF THIS DOCUMENT  
 MUST BE AUTHORIZED BY  
 APPROPRIATE APPROVAL AGENCIES

- 4). D.S. COMPONENTS R15, R18, R35, C24, AND C34 ARE NOT PRESENT.
- 3). ALL RESISTORS ARE IN OHMS.
- 2). ALL CAPACITORS ARE IN MFD.
- 1). ALL RESISTORS ARE 1/4W, 1%, 50ppm/°C
- NOTES: UNLESS OTHERWISE SPECIFIED.

SCHEMATIC NAME: 500 WATT POWER SUPPLY FOR		PART NO. 3600-0010	
UNIVERSAL ANALYZERS INC.		DATE: 8/8/92	DWN/RRM
		C E0012	CHK TB
SHEET 1 OF 1		APV TB	
		ENG TB	

REV	DATE	CHANGE	REV	DATE	CHANGE
D	5/27/98	C35 TO 47pf	C	6/7/95	RH1 TO CL10
			B	9/30/93	
			A	9/1/93	

# Universal Analyzers Inc.

## SPARE PARTS RECOMMENDATIONS FOR MODEL 1090

<b><u>Level A, Consumable Parts (All Models):</u></b>		<b><u>2 Yr Req.</u></b>
3010-0003	Fuse, Control Board – 2 Amp Slow Blow	2
3010-0006	Fuse, Power Supply Board – 12 Amp	2
<b><u>Level B, Basic Parts (Model 1090SS):</u></b>		
5200-S010	Heat Exchanger/Impinger – 316S.S. 10 Inch	
4904-0013	O-Ring, 316S.S. Heat Exchanger – Viton 2-021	4
8010-0001	Paste, Heat Sinking - 0.1 Ounce Container	2
<b><u>Level B, Basic Parts (Model 1090PV):</u></b>		
5200-K010	Heat Exchanger/Impinger – Glass/Kynar 10 Inch	
5201-0001	Glass Tube, Outer – Heat Exchanger Replacement 10 Inch	2
4904-0003	O-Ring, Glass/Kynar Heat Exchanger – Viton 2-018	4
4904-0004	O-Ring, Glass/Kynar Heat Exchanger – Viton 2-120	4
8010-0001	Paste, Heat Sinking - 0.1 Ounce Container	2
<b><u>Level C, Critical Parts (All Models):</u></b>		
3016-0002	Peltier Element, Pair - 15Vdc 8.5 Amp 40mm Sq.	
9515-0002	Insulation Kit - Heat Transfer Block	
1150-0016	Thermocouple, Type “K” - Peltier Control	2
4800-0003	Fan, Heat Sink Cooling	
4800-0005	Fan, Power Supply Cooling	
<b><u>Level D, In-Depth Parts (All Models):</u></b>		
3600-0002	Controller Circuit Board - Dual Channel	
3600-0007	Alarm Relay Circuit Board - Dual Channel	
3600-0010	Power Supply Board - 15Vdc 500 Watt	
<b><u>Optional Parts:</u></b>		
4958-0003	Motor, Peristaltic Pump - 120Vac 6RPM	1
4958-0006	Head, Peristaltic Pump - For #15 Tubing	
4958-0025	Sample Pump - 120Vac Mini Dia-Vac Alum/Teflon Single Head	
4958-0026	Sample Pump - 120Vac Mini Dia-Vac Alum/Teflon Dual Head	
4980-0005	WCOF Assembly - Visible Moisture Sensor/2µm Teflon Filter	
5205-0006	Bowl, WCOF Filter - Replacement with Cable	
4980-0006*	Filter Element - 2µm Teflon (WCOF)	6
9216-0002	Tube, Peristaltic Pump - 5 Feet Length #15	2
9515-0018	Sample Pump Rebuild Kit - Mini Dia-Vac	3
9515-0046	Thermocouple Kit, Heat Exchanger - “New Jersey” Type “K”	

\* Commissioning Spare Part

# UNIVERSAL ANALYZERS INC.

## MOISTURE CONVERSION TABLE

DEW POINT, DEGREES C.	% WATER BY VOLUME AT SATURATION	% WATER BY WEIGHT AT SATURATION	WATER VAPOR PRESSURE, mm. Hg
-100	0.00000139	0.00000081	0.0000099
-50	0.00388	0.00241	0.0295
-20	0.102	0.0633	0.776
-10	0.256	0.1596	1.950
-5	0.396	0.229	3.014
-4	0.432	0.268	3.280
-3	0.469	0.291	3.569
-2	0.510	0.317	3.880
1	0.555	0.345	4.223
0	0.602	0.364	4.579
1	0.649	0.404	4.937
2	0.696	0.433	5.294
3	0.750	0.466	5.70
4	0.803	0.499	6.10
5	0.861	0.535	6.54
6	0.922	0.573	7.01
7	0.988	0.614	7.51
8	1.06	0.658	8.05
9	1.13	0.702	8.58
10	1.21	0.753	9.15
11	1.29	0.802	9.8
12	1.38	0.860	10.5
13	1.48	0.920	11.2
14	1.58	0.980	12.0
15	1.68	1.044	12.8
20	2.31	1.433	17.5
25	3.13	2.004	23.8
30	4.19	2.64	
35	5.55	3.54	
40	7.28	4.67	
45	9.46	6.12	
50	12.2	8.0	
55	15.5	10.3	
60	19.7	13.3	
65	24.4	16.8	
70	30.7	21.7	
75	38.0	27.8	
80	46.7	35.6	
85	57.2	45.7	
90	69.2	58.4	