

NOW A

**MOORE
INDUSTRIES**
The Interface Solution Experts

PRODUCT!

5 3 2



532

► 1/4 DIN Auto/Manual Station

**MOORE
INDUSTRIES**

The Interface Solution Experts

GENERAL DESCRIPTION

The 532 Auto/Manual Station ensures the integrity of your processes with maximum reliability. Isolated inputs and outputs guard against electrical interference, the front face meets NEMA 4X standards for watertight operation, and solid metal housing and sturdy rubber keys enhance durability.

The 532 has been engineered to be the industry's most user friendly and comprehensive Auto/Manual Station. It has three digital display areas, with two offering up to 9 characters of true alphanumerics. The bright, crisp vacuum fluorescent display offers better readability than any other display technology. Additional operator friendly features include: custom programmable alarm messages, keys that illuminate when in use and an easy-to-use menu system.

532 AUTO/MANUAL BACKUP STATION

The 532 provides manual backup for critical control loops. In HOST mode, the control signal passes from the Host device through the 532 without any degradation. A Host device may be a PLC, DCS or process controller. The 532 switches to LOCAL mode upon keypad selection, digital input or loss of the Host signal. The 532 generates a control signal based on a predetermined control value (CV), or the last known CV from the Host. The operator can modify CV with the ▲ and ▼ keys. The 532 will transfer to HOST mode upon keypad selection, opening of the digital input or return of the Host signal. Removal of the 532 from its case or powering down while in HOST mode will not disturb the Host signal; the 532 is not a point of failure!

532 AT A GLANCE

- ▶ Provides manual backup of critical control loops.
- ▶ Transfers between REMOTE and LOCAL modes via keypad command, digital input, RS-485 Communications or loss/return of control signal.
- ▶ Upon keypad command or loss of signal, generates a control signal based on the last known HOST value or a preprogrammed value.
- ▶ Can utilize a programmable rate-of-change ramp when switching to a preprogrammed control value (CV) or returning to REMOTE mode.
- ▶ Provides an alarm output in LOCAL mode for status.
- ▶ Display function always shows the Control Value (CV), and will show the process variable (PV) and Setpoint (SP) or Valve Position (VP) if desired.
- ▶ Accepts a retransmitted PV or direct input of thermocouples, RTDs and linear signals.

BOTH

- ▶ Unique, bolted "clamshell" front panel provides NEMA 4X watertight rating. You can hose down the 532 with the rest of your equipment.
- ▶ Illuminated raised rubber keys yield much longer life than common dome-type keys, provide excellent tactile feel, and are easily read in the dark.
- ▶ Optional RS-485 serial communications with baud rates up to 19,200 will allow you to monitor your process from a personal computer or other host.
- ▶ Vacuum fluorescent display features a single large five-digit display and two nine character lines of alphanumerics.
- ▶ Recessed area below the display accommodates a nomenclature tag.

SPECIFICATIONS

ACCURACY

	TYPICAL	MAXIMUM
LINEAR		
(Voltage)	± 0.025% full scale	± 0.100% full scale
(Current)	± 0.050% full scale	± 0.150% full scale
RTD		
1°	± 0.050% of span	± 0.150% of span
0.1°	± 0.095% of span	± 0.225% of span
THERMOCOUPLE		
J, K, N, E (> 0°C)	± 0.060% of span	± 0.150% of span
J, K, N, E (< 0°C)	± 0.150% of span	± 0.375% of span
T (> 0°C)	± 0.100% of span	± 0.250% of span
T (< 0°C)	± 0.250% of span	± 0.625% of span
R, S (> 500°C)	± 0.150% of span	± 0.375% of span
R, S (< 500°C)	± 0.375% of span	± 0.925% of span
B (> 500°C)	± 0.150% of span	± 0.375% of span
B (< 500°C)	± 0.500% of span	± 1.000% of span
W, W5 & Platinel II	± 0.125% of span	± 0.325% of span

Display accuracy is ± 1 digit. These accuracy specifications are at reference conditions (25°C) and only apply for NIST ranges.

Detailed accuracy information is available upon request.

ISOLATION

Inputs and outputs are grouped into the following blocks:

Block 1 — process variable indication

Block 2 — outputs 1, 2, and 4

Block 3 — communications, set of 3 digital inputs, output 3

Block 4 — setpoint and indicator

Each block is electrically isolated from the other blocks to withstand a HIPOT potential of 500 Vac for 1 minute or 600 Vac for 1 second, with the exception of blocks 1 and 4, which are isolated to withstand a HIPOT potential of 50 volts peak for 1 minute between each other. Inputs and outputs are not isolated from other inputs and outputs within the same block.

PROCESS VARIABLE INDICATOR INPUTS

Universal input type. Any input type may be selected in the field. Selection of input type (thermocouple, RTD, voltage or current) via jumper. Selection of particular sensor or range is via front panel.

THERMOCOUPLES	RANGE °F	RANGE °C
B	104 to 3301	40 to 1816
E	-454 to 1832	-270 to 1000
J	-346 to 1832	-210 to 1000
K	-418 to 2500	-250 to 1371
N	-328 to 2372	-200 to 1300
R	32 to 3182	0 to 1750
S	32 to 3182	0 to 1750
T	-328 to 752	-200 to 400
W	32 to 4172	0 to 2300
W5	32 to 4172	0 to 2300
Platinel II	-148 to 2550	-100 to 1399

RTD'S	RANGE °F	RANGE °C
100 ohm Pt. (DIN)	-328 to 1562	-200 to 850
	-328.0 to 545.0	-200.0 to 285.0
100 ohm Pt. (JIS)	-328 to 1202	-200 to 650
	-328.0 to 545.0	-200.0 to 285.0
100 ohm Pt. (SAMA)	-328 to 1202	-200 to 650
	-328.0 to 545.0	-200.0 to 285.0

TRANSMITTER SIGNALS	INPUT RANGE
Milliamps DC	4 to 20 0 to 20
Voltage DC	1 to 5 0 to 5
Millivolts DC	0 to 10 0 to 30 0 to 60 0 to 100 -25 to 25

LINEARIZATION

Thermocouple and RTD inputs are automatically linearized.

Transmitter inputs may be linearized with a square root function or user-defineable 15-point straight line linearization function.

INPUT IMPEDANCE

Current Input: 250 ohms Thermocouples: 10 Mohms

Voltage Input: 1 Mohm RTDs: 10 Mohms

UPDATE RATE

Input is sampled and output updated 5 times per second. Display is updated 5 times per second. Passage of the HOST signal through the 532 is continuous.

INPUT FILTER

Single pole lowpass digital filter with selectable time constant from 0 to 120 seconds.

CALIBRATION

The station comes fully calibrated from the factory and continuously calibrates itself for component aging due to temperature and time, except for reference voltage. Field calibration can be performed easily with a precision multimeter and thermocouple simulator. Process variable offset and gain factors are provided to correct for sensor errors.

OUTPUT MODULE

One analog output (CV), 4–20 mA into a load up to 1000 ohms.

Also available is solid state relay, DC logic, or an additional mechanical relay module that can be tied to an alarm.

CONTROL OUTPUT

Manually adjusted 4–20mA into a load up to 1000 ohms.

ALARMS

The 532 has two powerful software alarms. The 532 provides a LOCAL alarm that indicates when the 532 is in LOCAL mode. When tied to an available output, the HOST device can be flagged as to the change in status. If the PV indicator option is used, a PV High, PV Low and Rate alarm are available. If the SP indication option is also chosen, a SP Band and SP Deviation alarm are also available. A 9-character custom alarm message is available for each alarm.

DIGITAL INPUTS

A set of three external dry contacts or open collector driven transistor inputs are available. Each can be configured to perform one of the following functions:

- Select LOCAL control with LAST-OUT or 1 of 2 preset values
- Acknowledge alarms
- Addressable through serial communications only
- ▲/▼ Key Emulation

SERIAL COMMUNICATIONS

Isolated serial communications is available using an RS-485 interface. Baud rates of up to 19,200 are selectable. The protocol supports CRC data checking. Output 1 on the 532 can act as "host controller," I/O independent of the controllers functions. May be installed in the field.

DIGITAL DISPLAYS

Displayed information depends upon chosen options.

Upper display: Five-digit, seven-segment. If the PV option is chosen, displays PV. Normally displays CV in 0.1% increments. Height is 15 mm (0.6 in.).

2nd display: nine-character, 14-segment alphanumeric. If 1st display indicates PV, 2nd indicates SP or valve position (VP) (transmitted from host), or CV. If the SP option is chosen, display will automatically alternate between SP and CV every 2 seconds. During set-up, displays configuration information. Height is 6 mm (0.25 in.).

3rd display: nine-character, 14-segment alphanumeric. When no alarm messages are queued, indicates a user selectable "station" name. During set-up, displays configuration information. Height is 6 mm (0.25 in.).

All displays are vacuum fluorescent. Color is blue-green.

STATUS INDICATORS

ALM 1 icon illuminated: alarm status

HOST key illuminated: CV signal from HOST is present

LOCAL key illuminated: 532 is in LOCAL mode

ACK key illuminated: alarm is acknowledged

MENU key illuminated: 532 is in configuration mode

DIMENSIONS

Meets 1/4 DIN designation as specified in DIN standard number 43 700. See diagram for details.

MOUNTING

Panel-mounted. See diagram for details.

WIRING CONNECTIONS

29 screw terminals in the rear of the instrument.

POWER CONSUMPTION

15 VA at 120 VAC, 60 Hz (typical).

WEIGHT

Approximately 1 kg (2.2 lbs.).

AMBIENT TEMPERATURE

Operative Limits: 0 to 50°C (32 to 122°F).

Storage Limits: -40 to 70°C (-40 to 158°F).

RELATIVE HUMIDITY

10 to 90%, non-condensing.

POWER INPUT

Universal power supply: 90 to 250 VAC, 48 to 62 Hz.

NOISE IMMUNITY

Common mode rejection (process input): >120 dB.

Normal mode rejection (process input): >80 dB.

AC line is double filtered and transient protected. Internal snubbers are provided for each relay output.

CONSTRUCTION

Case: extruded, non-perforated black anodized aluminum with ABS plastic sleeve.

Bezel: black plastic ABS.

Chassis assembly: plug-in type.

Keys: silicone rubber with diffusion printed graphics.

NEMA rating: front panel conforms to NEMA 4X when instrument is properly installed.

AGENCY APPROVALS



LR 84603



LISTED
Process Control Equipment
4N66



(Heavy
Industrial)

(Available as an option)

MEMORY RETENTION

Lithium battery maintains all programming for approximately ten years.

SECURITY

There are two levels of access: restricted and full. A configurable code is used to enter the full access level. Functions not available in the restricted level are configurable.

TYPICAL APPLICATION

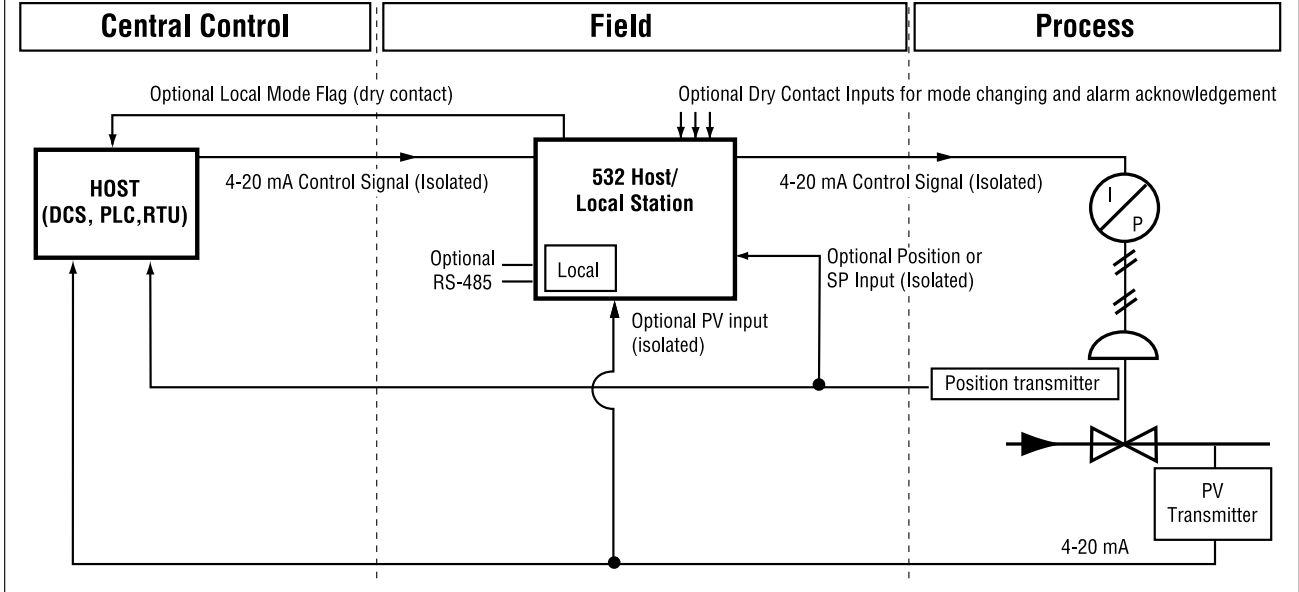

DIMENSIONS

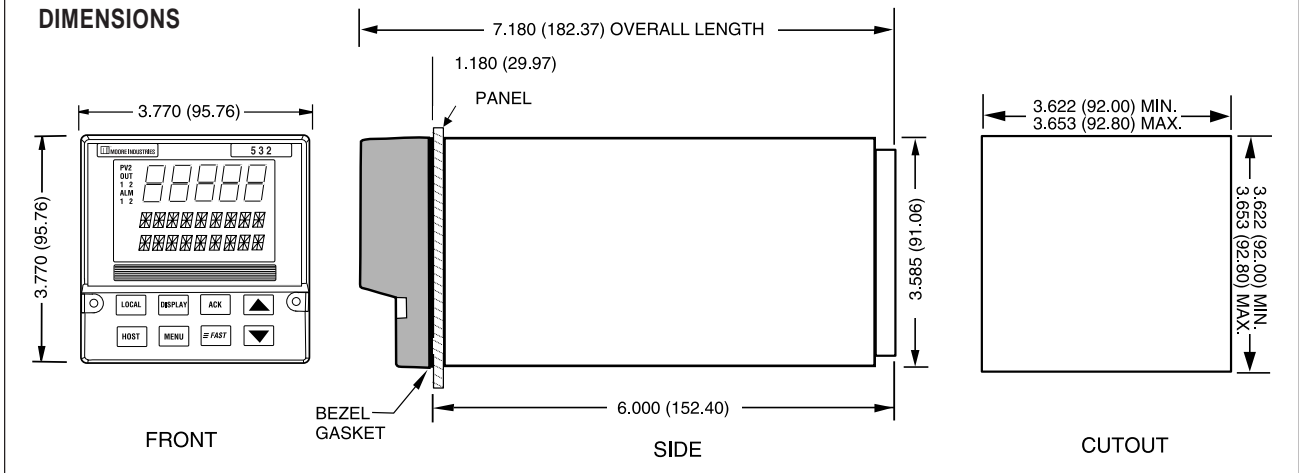

ORDERING INFORMATION
532—AUTO/MANUAL BACKUP STATION

OUTPUT 1 — ALARM

- None 0
- Mechanical relay 1
- Solid state relay (triac) (1 amp) 3
- DC logic (SSR drive) 4

One 4–20mA output module 2

PV indication (Standard) B

OPTIONAL INPUTS

ENTER "0" IF NOT DESIRED

Set of 3 digital inputs D

SERIAL COMMUNICATIONS

ENTER "0" IF NOT DESIRED

RS-485 serial communications S

532 - 2 1 1 0 B 0 0

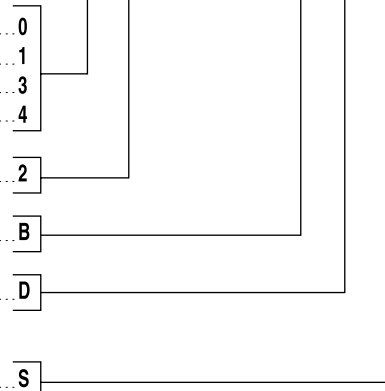

Contact Esys for more information about this product:
 Esys® The Energy Control Company™
 4520 Stine Road, Ste 7
 Bakersfield, CA 93313
 (661) 833-1902

email: esys@esys.us
 website: <http://www.esys.us>

