

General Installation Instructions

Please read all installation and start-up instructions prior to working with the SMARTFIRE™ Intelligent Combustion Control System. A view port providing a clear view of the entire flame is strongly recommended.

Do not discard packing material until all parts have been identified. Collect the five SMARTFIRE™ components required for controlling a burner (or zone of burners):

1. Interface Panel (includes the Burner Brain, User Interface Terminal, and 24 VDC Power Supply)
2. Air Valve Actuator
3. Fuel Valve Actuator
4. Air Flow Controller (comprised of a sensor probe and attached electronics in a flow body)
5. Fuel Flow Controller (comprised of a sensor probe and attached electronics in a flow body)

A typical SMARTFIRE™/burner/piping layout is shown below.

Verify that all Maxon System Numbers and Burner Model Identifiers are the same. Because all SMARTFIRE™ Systems are pre-configured at the factory for a given burner system, this installation step is very important to ensure proper operation.

The SMARTFIRE™ Intelligent Combustion Control System accounts for a portion of the total combustion system. The sizing and installation instructions for other components such as burners, blowers, and regulators can be found in the corresponding sections of the Maxon catalog.

Typical SMARTFIRE™/Burner/Pipetrain Layout

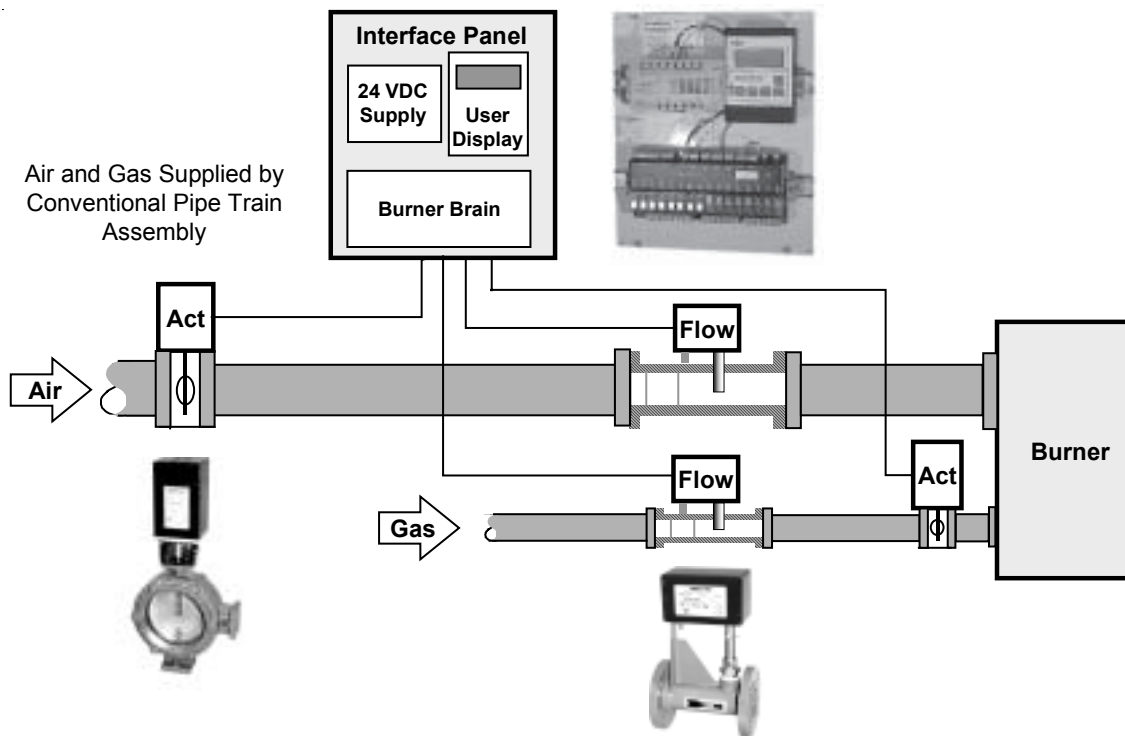

Contact Esys for more information about this product:
 Esys® The Energy Control Company™
 4520 Stine Road, Ste 7
 Bakersfield, CA 93313
 (661) 833-1902

email: esys@esys.us
 website: <http://www.esys.us>



General Installation Instructions

The SMARTFIRE™ System can be installed as a new or retrofit system. Installation is straightforward and can be accomplished in a working day for most applications. The major tasks involve installing the four field devices and mounting the SMARTFIRE™ Interface Panel. These tasks are described in the following sections:

- *Mechanical Installation Instructions*
(pages 7200-S-3 to 5)
- *Electrical Installation Instructions*
(pages 7200-S-6 to 15)

The Interface Panel and the four field devices can be installed in any sequence.

WARNING

The SMARTFIRE™ System is not a safety device. The System provides cross-limited air/fuel ratio control and performs many redundant and physically diverse diagnostic tests during operation. However, in accordance with NFPA (National Fire Protection Agency) guidelines and other local and national safety codes, the User should provide appropriate safety equipment such as flame safeguard, high temperature limits, oxygen sensors, or redundant air and fuel flow sensors, as required.

Before performing the installation steps described in these sections, please note the following general guidelines and safety instructions:

- Validate the air and fuel flow measurements during commissioning by using the pressures at the burner.
- The SMARTFIRE™ Interface Panel must be mounted in a protected enclosure.
- Check for air and fuel leaks **before** the burner is started.
- **CAUTION:** Never place hands or fingers in the Valve Actuators/Valve Assemblies.
- If the piping requirements outlined in the *Mechanical Installation Instructions* (Page 7200-S-3) cannot be achieved within the User's allocated space for the combustion system, call **Maxon SMARTFIRE™ Support at 800-652-3553** (within the United States or Canada).
- Eliminate any construction debris from the fuel and air pipetrains before installing the Flow Controllers to prevent blockages in the flow conditioning screens.
- Verify that the combustion air blower is properly filtered. (Proper filtering ensures that the air sensing probe of the SMARTFIRE™ Flow Controller is not contaminated by particulate matter or water.)
- Verify that the gas regulator is sized for both the maximum and minimum fuel flow required by the burner and/or application.

After the installation steps are completed, follow the SMARTFIRE™ checkout and startup procedures provided in the **Start-up and Operation Instructions** (Page 7200-S-16 to 21).



Contact Esys for more information about this product:
 Esys® The Energy Control Company™
 4520 Stine Road, Ste 7
 Bakersfield, CA 93313
 (661) 833-1902

email: esys@esys.us
 website: <http://www.esys.us>



Mechanical Installation Instructions

Requirements

When installing the SMARTFIRE™ Air and Fuel Flow Controllers and the Air and Fuel Valve Actuators, please note the following:

- The arrow on the side of each Flow Controller should be oriented in the direction of flow.
- The Flow Controllers and the Valve Actuators can be mounted in any orientation.
- Refer to the *Electrical Installation Instructions* (pages 7200-S-6 to 7200-S-15) for cable and wiring requirements for each of the field devices. Maintain proper wire color code for 24 Volt DC Power and Data Communication Signals.

In cases where replacement Flow Controller air and/or fuel sensor probes (with their attached electronics) need to be installed in their respective flow bodies, loosen the compression fitting sufficiently to insert the sensor probe and alignment pin into the flow body. The probe assembly should sit flush against the flow body's horizontal mounting flange and should not be cocked at an angle. The compression fitting is then tightened.

The following piping guidelines for the SMARTFIRE™ field devices ensure that the gas and air flow can be properly measured and controlled. Flow control accuracy is essential for optimum burner performance. **If the piping requirements outlined in the *Air Piping Guidelines* and/or *Gas Piping Guidelines* cannot be achieved within the space allocated for the combustion system, call Maxon SMARTFIRE™ Support at 800-652-3553 (within the United States or Canada).**

Air Piping Guidelines

Air piping between the combustion blower and the burner should be constructed using the following guidelines:

- Locate the SMARTFIRE™ Air Valve Actuator at a maximum distance of 10 blower outlet diameters from the combustion blower. This configuration prevents blower pulsation (effects) created by the blower and air piping at low flow rates.
- If Maxon is not supplying the blower, the User should contact the blower manufacturer for the maximum recommended distance (for a specific pipe diameter) between the blower outlet and a control valve (i.e., the SMARTFIRE™ Air Valve Actuator) to prevent Helmholtz effect.
- The SMARTFIRE™ Air Flow Controller is installed downstream of the air valve actuator. It requires a total straight piping run of 14 flow body diameters (including approximately 4 diameters for the Flow Controller) to ensure accurate air flow control. See installation schematic on page 7200-S-4:
 1. A minimum of seven (7) "straight" diameters are required upstream of the Air Flow Controller.

$$\text{Minimum length of pipe} = 7 \times \text{the air flow body diameter}$$

"Straight" diameter piping is defined as same diameter pipe with no elements such as valves, flanges, orifice plates, or bends within the specified pipe length.

2. Exceed the above minimum requirement by as many straight diameters as space permits (i.e., maximize the number of straight diameters upstream of the Air Flow Controller). This length ensures that the air stream can be properly conditioned and measured by the Air Flow Controller.
3. A minimum of three (3) "straight" diameters are required downstream of the Air Flow Controller.

$$\text{Minimum length of pipe} = 3 \times \text{the air flow body diameter}$$

- Because the blower is rotational machinery, dampening pads for the blower stand and a flexible (bellows-type or braided stainless hose) connection from the blower discharge to the air piping are recommended.



Contact Esys for more information about this product:
 Esys® The Energy Control Company™
 4520 Stine Road, Ste 7
 Bakersfield, CA 93313
 (661) 833-1902

email: esys@esys.us
 website: <http://www.esys.us>



Mechanical Installation Instructions

SMARTFIRE™ Air Piping Specification

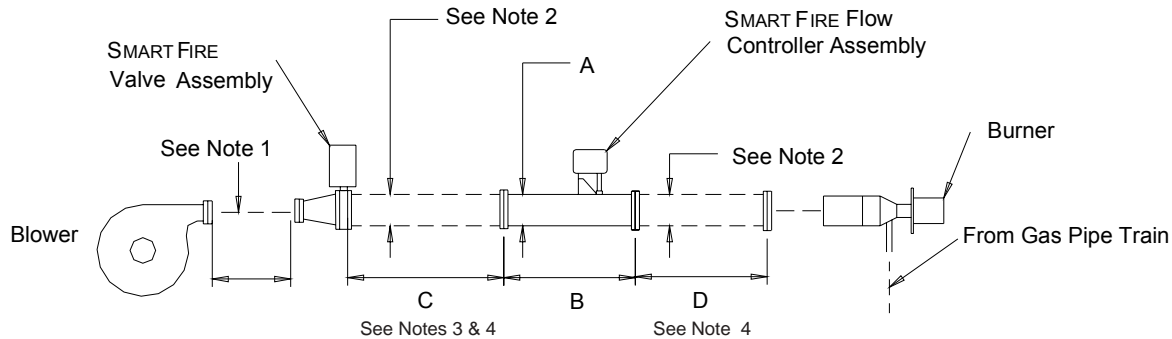

Note 1: For Maxon blowers, piping distance between the blower and the control valve must not exceed 10 times the blower outlet diameter. For non-Maxon blowers, contact the blower manufacturer for the maximum recommended length for the blower outlet size to prevent Helmholtz effects.

Note 2: Piping diameters should match the Flow Controller's ID

Note 3: Maximize the straight length of Dimension C (space permitting)

Note 4: Piping sections dimensioned C and D are customer-supplied

Flow Controller and Pipetrain Dimensions

Air Flow Controller Size	Maxon Flow Controller P/N	A Flow Controller OD/ID (inches)	B Flow Controller Length (inches)	Flow Controller Flange ID/OD (inches)	Flow Controller Flange Bolt Circle (inches)	Flange Hole Size	Flow Controller Flange No. of Holes Equally Spaced	C Minimum Length (inches)	D Minimum Length (inches)
8	SF SAC	8.63/8.42	34.0±.03	8.12/10.62	9.5	0.406	8	59	26
12	SF SAC	12.75/12.54	50.0±.05	12.19/15.19	13.81	0.406	12	88	38
16	SF SAC	16.00/15.76	64.0±.06	16.25/19.75	18.13	0.406	16	111	48
20	SF SAC	20.00/19.76	80.0±.08	20.25/23.75	22.13	0.406	20	139	60
24	SF SAC	24.00/23.76	96.0±.10	24.25/27.75	26.13	0.562	20	167	72
28	SF SAC	28.00/27.77	96.0±.10	28.25/32.25	30.5	0.625	24	195	84

Flange per Chicago Metal Rolled Products: (773-523-5757)



Contact Esys for more information about this product:
 Esys® The Energy Control Company™
 4520 Stine Road, Ste 7
 Bakersfield, CA 93313
 (661) 833-1902

email: esys@esys.us
 website: <http://www.esys.us>



Mechanical Installation Instructions

Gas Piping Guidelines

Gas piping between the fuel train and burner should be constructed using the following guidelines:

- Locate the SMARTFIRE™ Fuel Flow Controller downstream of the gas regulator and upstream of the gas valve actuator.
- The SMARTFIRE™ Fuel Flow Controller requires a total straight piping run of 14 flow body diameters (including approximately 4 diameters for the Flow Controller) to ensure accurate fuel flow control. See installation schematic below:
 1. A minimum of five (5) “straight” diameters are required upstream of the Fuel Flow Controller.

*Minimum length of pipe =
5 x the fuel flow body diameter*

“Straight” diameter piping is defined as same diameter pipe with no elements such as valves, flanges, orifice plates, or bends within the specified pipe length.

2. Exceed the above minimum requirement by as many straight diameters as space permits (i.e., maximize the number of straight diameters upstream of the Fuel Flow Controller). This length ensures that the gas stream can be properly conditioned and measured by the Fuel Flow Controller.
3. A minimum of five (5) “straight” diameters are required downstream of the Fuel Flow Controller.

*Minimum length of pipe =
5 x the fuel flow body diameter*

SMARTFIRE™ Gas Piping Specification

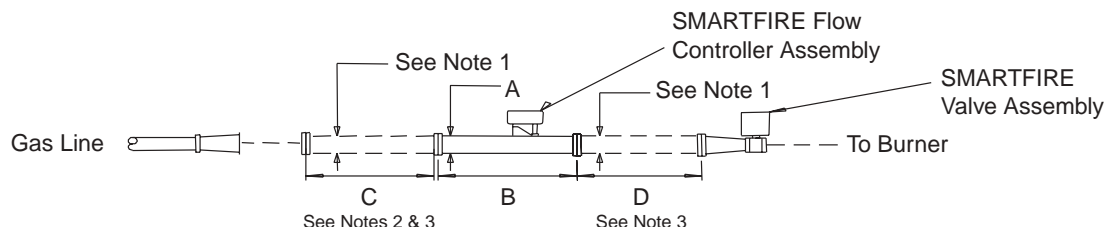

- Note 1:** Piping diameters should match the Flow Controller’s ID
Note 2: Maximize the straight length of Dimension C (space permitting)
Note 3: Piping sections dimensioned C and D are customer-supplied

Pipetrain Dimensions

Flow Controller Size	Oxy Flow Controller P/N	Fuel Flow Controller P/N	A Flow Controller OD (inches)	B Flow Controller Length (inches)	C Minimum Length (inches)	D Minimum Length (inches)	ANSI Flange Rating (pounds)
2	SF SSOC	SF SNC	2.38	8 ± .02	12	12	150
3	SF SSOC	SF SNC	3.5	12 ± .02	18	18	150
4	SF SSOC	SF SNC	4.5	16 ± .02	23	23	150
6	SF SSOC	SF SNC	6.63	24 ± .02	32	32	150

Schedule 40 Pipe



Contact Esys for more information about this product:
 Esys® The Energy Control Company™
 4520 Stine Road, Ste 7
 Bakersfield, CA 93313
 (661) 833-1902

email: esys@esys.us
 website: <http://www.esys.us>



Electrical Installation Instructions

System Wiring Requirements

The following block diagram indicates the major sources and destinations of the electrical wiring required by the SMARTFIRE™ System. The System wiring is divided into the following four categories:

- Burner management AC control wiring to/from the SMARTFIRE™ Burner Brain.
- Current loop (4-20 mA) control and monitoring wiring from a User's temperature controller and/or DCS system to the SMARTFIRE™ Burner Brain.

- Network wiring from the SMARTFIRE™ Burner Brain to the SMARTFIRE™ Field Devices.
- Power and network wiring between the SMARTFIRE™ Burner Brain and the 24VDC Power and the User Display. These connections are factory wired on the SMARTFIRE™ Interface Panel.

A complete set of wiring schematics describing how SMARTFIRE™ is interfaced to a "typical" burner management system is shown in the following pages.

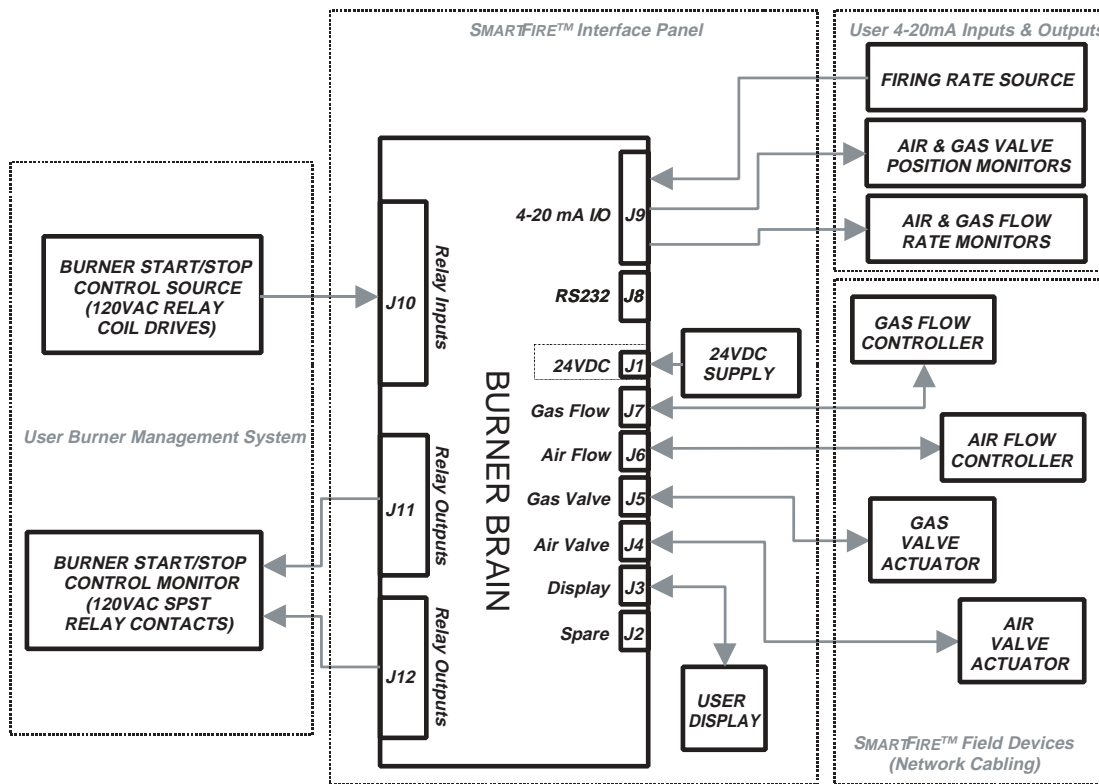

Contact Esys for more information about this product:
 Esys® The Energy Control Company™
 4520 Stine Road, Ste 7
 Bakersfield, CA 93313
 (661) 833-1902

email: esys@esys.us
 website: <http://www.esys.us>



Electrical Installation Instructions

Typical SMARTFIRE™ Wiring Schematic

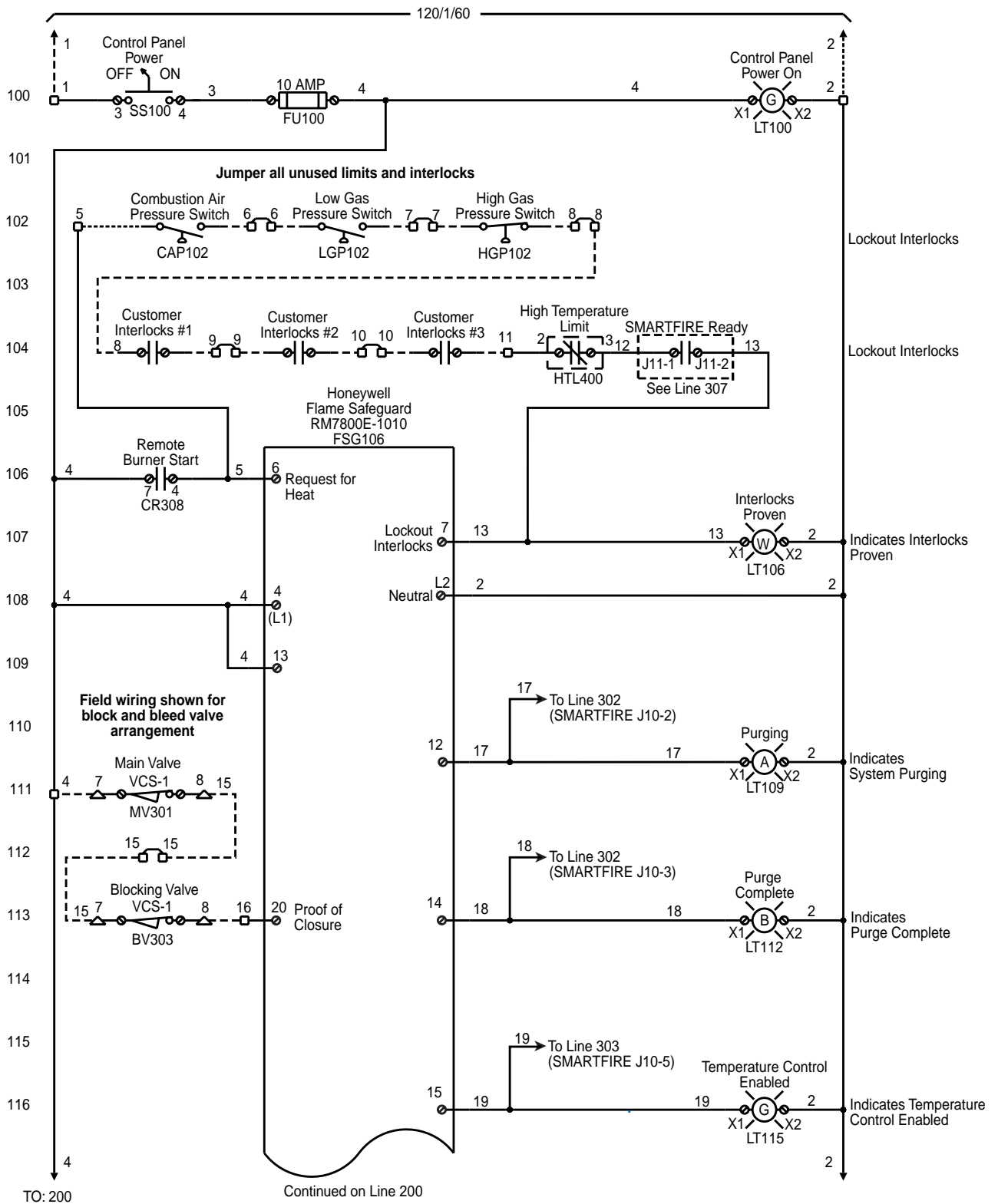

Electrical Installation Instructions

Typical SMARTFIRE™ Wiring Schematic (Continued)

Continued From Line 116

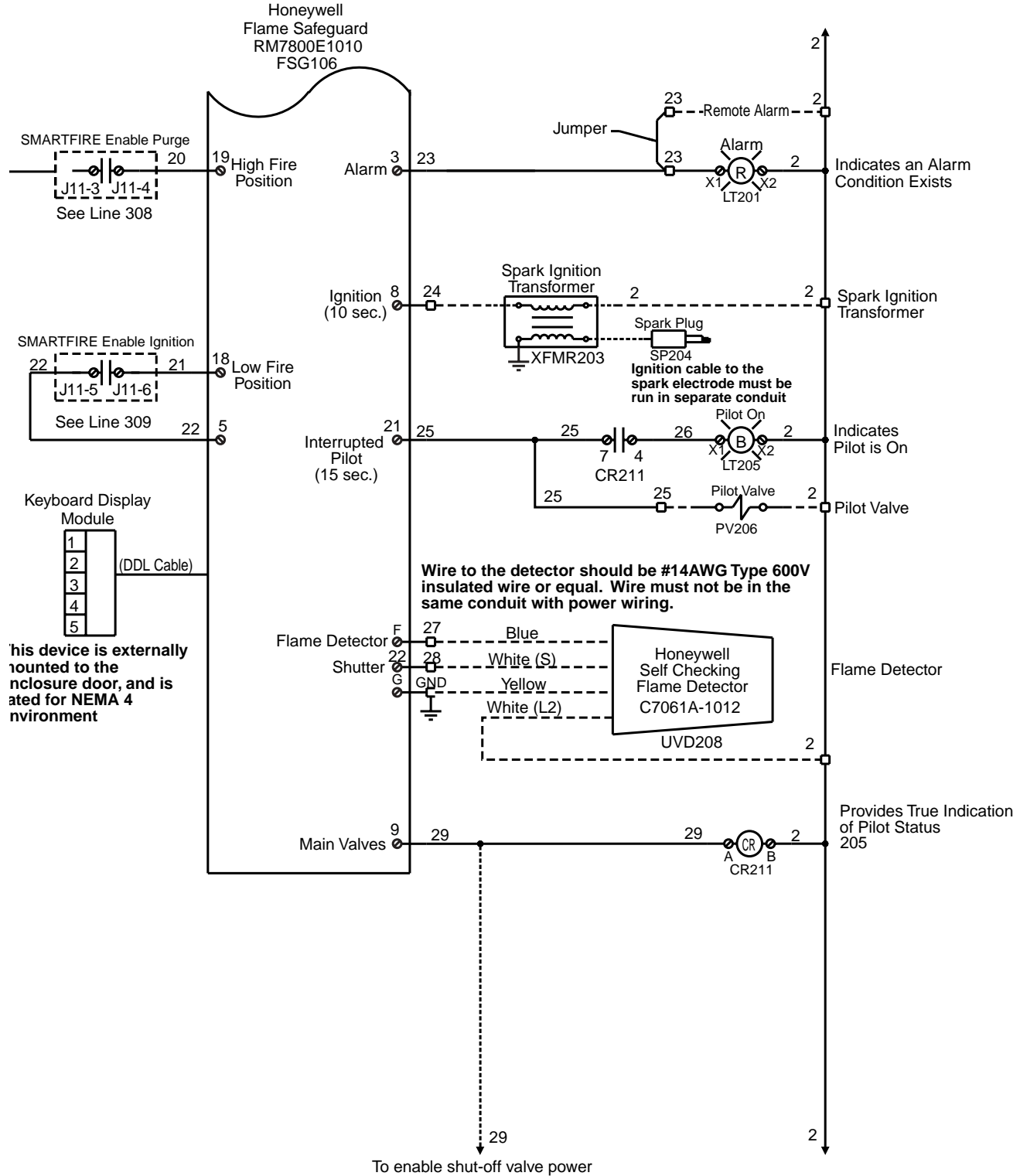

Electrical Installation Instructions

Typical SMARTFIRE™ Wiring Schematic (Continued)

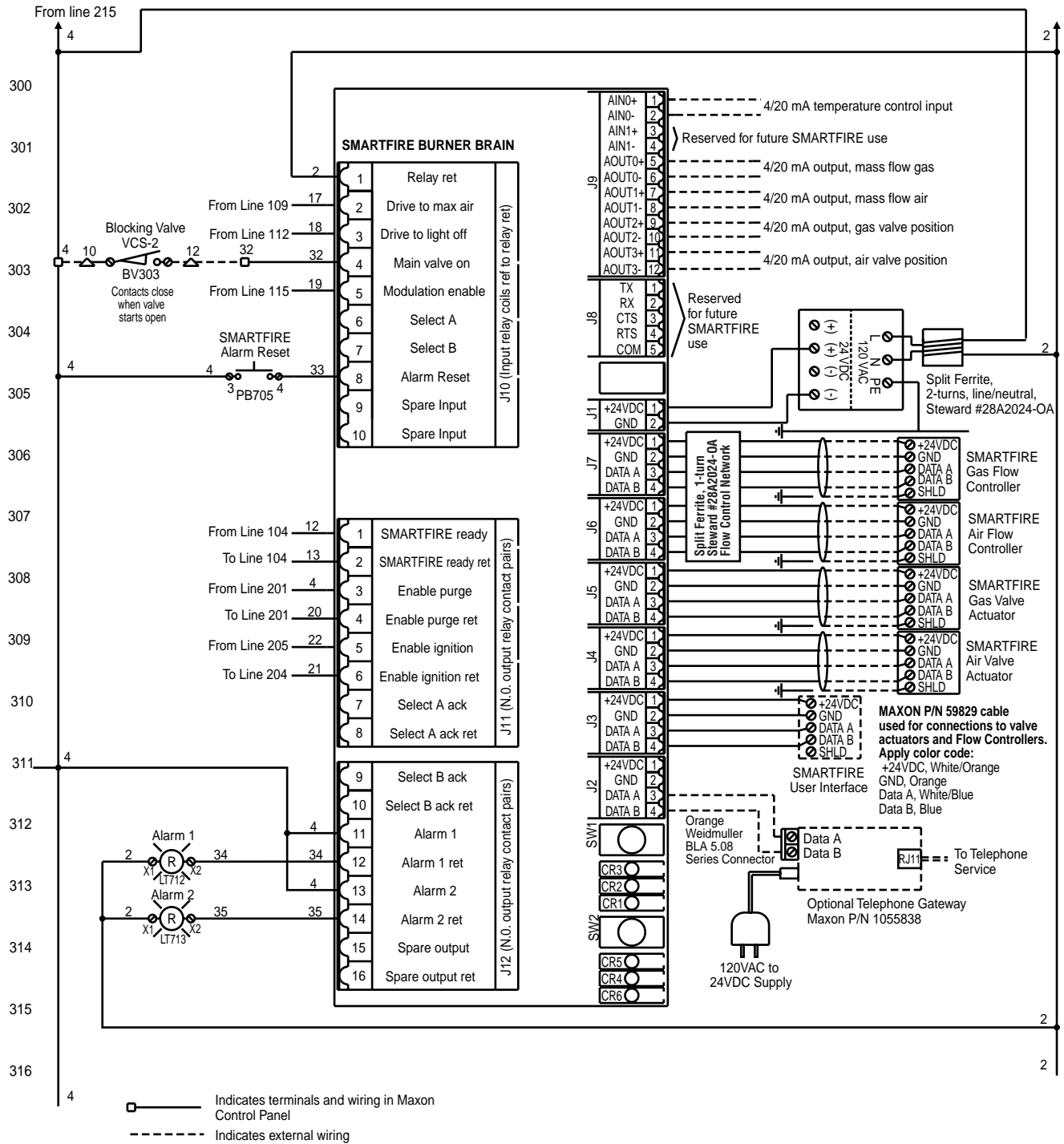

Contact Esys for more information about this product:
 Esys® The Energy Control Company™
 4520 Stine Road, Ste 7
 Bakersfield, CA 93313
 (661) 833-1902

email: esys@esys.us
 website: <http://www.esys.us>



Electrical Installation Instructions

Field Device Wiring Requirements

A four-conductor cable with an outer shield is required between the SMARTFIRE™ Burner Brain and each of the four SMARTFIRE™ field devices (four field cables are required, one for each field device). A fifth cable of the same type is provided (pre-wired) with the Interface Panel. It connects the Burner Brain to the User Interface Terminal. An optional sixth cable can be run for connection to a remote display or to connect to a telephone gateway for remote monitoring by Maxon field support personnel.

The recommended cable can be purchased from Maxon (P/N 59829) in a 500-foot spool, or it can be supplied in longer lengths (Connect-Air P/N W22P-1005) by contacting the following manufacturer.

Connect-Air International, Inc.
4240 "B" Street NW
Auburn, Washington 98001
Phone: 800-247-1978

The shields of each field cable should be terminated just as the cable enters the enclosure that houses the Interface Panel. Shield wire length should not exceed 2 inches.

Maxon recommends all SMARTFIRE™ field device cables be routed through a dedicated conduit or at least one that carries only low voltage, instrumentation signals.

Typically, flex conduit is used at each field device. The flex conduits feed a common steel conduit or cable tray that is run to the combustion panel. The SMARTFIRE™ control cable conduit(s) should not share the same conduit with any AC wiring or be in close proximity to the burner ignition cable. **All wiring should be done in accordance with all applicable local and national electric codes.**

The maximum total length of the recommended Maxon cable (P/N 59829) must be:

- Less than a total length of 1100 feet
- No single cable run to a SMARTFIRE™ Flow Controller, remote User Display Terminal, or Digital Gateway greater than 300 feet
- No single cable run to a SMARTFIRE™ Valve Actuator greater than 100 feet.

If any single cable run to a SMARTFIRE™ Valve Actuator exceeds 100 feet in length but is less than 300 feet, Belden Cable #3086A should be ordered. Belden product distribution information is available at 1-800-BELDEN-1 or www.belden.com.

If a single cable run to any SMARTFIRE™ device must exceed 300 feet, call the Maxon Product Support Team at 1-800-652-3553 within the United States or Canada.

The Burner Brain diagram on the following page shows all input/output terminations to the User's burner management system and field device cable terminations for the SMARTFIRE™ Valve Actuators and Flow Controllers. The tables on pages 7200-S-12 through 7200-S-15 explain the function of all inputs and outputs and network wiring color code.

It is the responsibility of the User to ensure that Maxon's SMARTFIRE™ Burner Brain is wired correctly to the proper burner start-up sequencing logic and combustion safety interlocks as required by local and national safety codes.

The User's burner management system and all related electrical control drawings that incorporate Maxon's SMARTFIRE™ Combustion Control System should be reviewed by qualified personnel knowledgeable in all relevant safety and industrial combustion requirements.

Contact Esys for more information about this product:

Esys® The Energy Control Company™
4520 Stine Road, Ste 7
Bakersfield, CA 93313
(661) 833-1902

email: esys@esys.us

website: <http://www.esys.us>



Electrical Installation Instructions

Burner Brain Interconnect Diagram

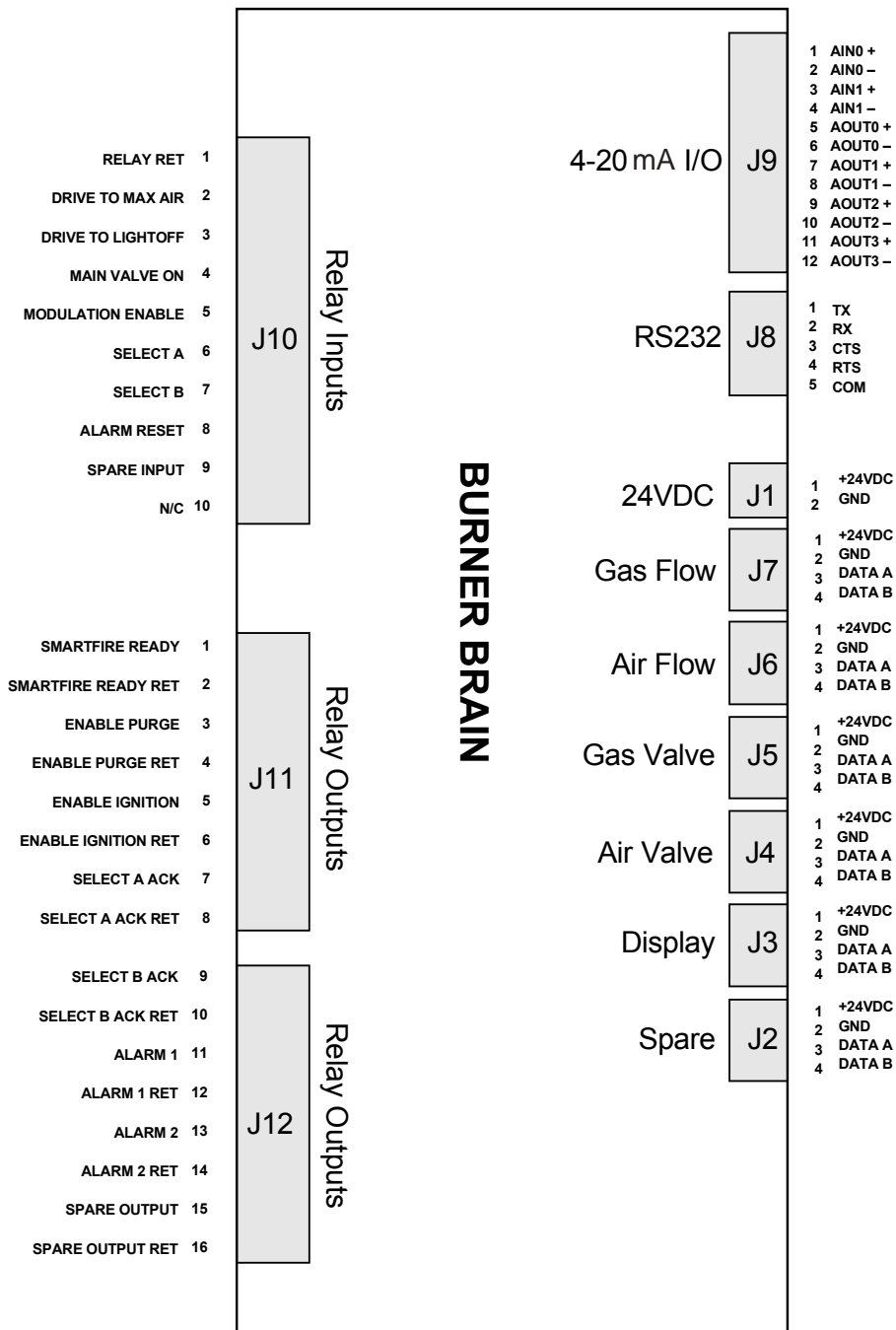

Contact Esys for more information about this product:
 Esys® The Energy Control Company™
 4520 Stine Road, Ste 7
 Bakersfield, CA 93313
 (661) 833-1902

email: esys@esys.us
 website: <http://www.esys.us>



Electrical Installation Instructions

SMARTFIRE™ Input/Output Signal Descriptions

Relay Inputs (120 VAC)

Signal Name	Terminal	Signal Function
RELAY RET	J10-1	Return for all 120VAC SMARTFIRE™ relay inputs.
DRIVE TO MAX AIR	J10-2	Commands SMARTFIRE™ to open its air valve to a full open position and checks air flow.
DRIVE TO LIGHTOFF	J10-3	Commands SMARTFIRE™ to position its fuel valve at 5 degrees and begins controlling air flow to the required starting flow setpoint.
MAIN VALVE ON	J10-4	Informs SMARTFIRE™ that the fuel shut-off valves have begun to open. Air/fuel ratio control is then enabled at the required starting firing rate.
MODULATION ENABLE	J10-5	Enables SMARTFIRE™ modulation of firing rate based on the 4-20mA firing rate input (J9-1, J9-2)
SELECT A	J10-6	Selects one of three SMARTFIRE™ air/fuel ratio curves installed in the Burner Brain or disables SMARTFIRE™ control. These selections are made as follows: - Default Operating Air/Fuel Ratio Curve is selected with no voltage applied to either input.
SELECT B	J10-7	- Curve No. 1 is selected with Select A at 120 VAC and Select B at 0 VAC. - Curve No. 2 is selected with Select A at 0 VAC and Select B at 120 VAC. - SMARTFIRE™ control disable is selected with 120 VAC on both inputs. The control disable function would be used during an on-line air/propane switch. This operational command is invalid during start-up.
ALARM RESET	J10-8	Resets all shutdown conditions, latched-air and fuel-limit alarms, and air and fuel flow check alarms. This reset function is performed when the SMARTFIRE™ Burner Brain senses a transition from 0 to 120 VAC.
SPARE INPUT	J10-9	Reserved for future use.
NO CONNECTION	J10-10	No connection.



Contact Esys for more information about this product:
 Esys® The Energy Control Company™
 4520 Stine Road, Ste 7
 Bakersfield, CA 93313
 (661) 833-1902

email: esys@esys.us
 website: <http://www.esys.us>



Electrical Installation Instructions

SMARTFIRE™ Input/Output Signal Descriptions

Relay Outputs (120 VAC)

Signal Name	Terminal	Signal Function
SMARTFIRE™ READY	J11-1	Closed output contact indicates at start-up the following conditions are satisfied: <ul style="list-style-type: none"> - All SMARTFIRE™ components are functioning properly. - Control valves are in their standby position. - SMARTFIRE™ System is ready to accept a "drive-to-maximum" air command.
SMARTFIRE™ READY RET	J11-2	After the pilot is lit and the main gas valve is opened by the burner management system, this output contact remains closed unless a shutdown condition or failure is detected. User-provided burner management hardware must employ the "SMARTFIRE™ Ready" output contacts as a start-up and running permissive.
ENABLE PURGE	J11-3	Output contact closes during the start-up sequence after the SMARTFIRE™ air valve reaches the full open position and air flow greater than 50 percent of the maximum flow required at high fire is measured by the air Mass Flow Controller.
ENABLE PURGE RET	J11-4	Contacts remain closed until SMARTFIRE™ detects an unsafe condition or until the burner is shutdown externally by the burner management system or User.
ENABLE IGNITION	J11-5	Closed output contact indicates when SMARTFIRE™ is in a "low-fire start" condition. The contacts close during the start-up sequence after the following conditions are achieved: <ul style="list-style-type: none"> - Starting air flow has been accomplished - Fuel control valve is in its starting position (5 degrees is default) - Gas flow in excess of 1/20th of the flow required for high fire is not present (i.e., no appreciable fuel leak exists).
ENABLE IGNITION RET	J11-6	Contact remains closed until SMARTFIRE™ detects an unsafe condition or until the burner is externally shutdown by the User or burner management system.
SELECT "A" ACK	J11-7	Close/open output contact combinations acknowledge which air/fuel ratio curve is selected or if SMARTFIRE™ control has been disabled. Refer to Select A and Select B inputs for contact combinations.
SELECT "A" ACK RET	J11-8	
SELECT "B" ACK	J12-9	
SELECT "B" ACK RET	J12-10	
ALARM 1	J12-11	Closed output contact indicates that the SMARTFIRE™ System detected a flow test alarm condition, shutdown, or device failure. Refer to "Command and Display" Function for a list of all alarm conditions.
ALARM 1 RET	J12-12	
ALARM 2	J12-13	Closed output contact indicates a lower level alarm condition that should be investigated to ensure proper system operation. Refer to "Command and Display" Functions for a list of all alarm conditions.
ALARM 2 RET	J12-14	
SPARE OUTPUT	J12-15	Reserved for future SMARTFIRE™ use.
SPARE OUTPUT RET	J12-16	



Contact Esys for more information about this product:
 Esys® The Energy Control Company™
 4520 Stine Road, Ste 7
 Bakersfield, CA 93313
 (661) 833-1902

email: esys@esys.us
 website: <http://www.esys.us>



Electrical Installation Instructions

4 to 20 mA Inputs/Outputs

Signal Name	Terminal	Signal Function
INPUTS		
AIN 0+ (FIRING RATE)	J9-1	A 4 to 20 mA input signal that establishes the burner's firing rate setpoint is as follows: - A 20 mA, full-scale signal represents a setpoint of 100 percent of the burner's maximum rated heat capacity. - A 4 mA signal represents the burner's minimum heat capacity. The User's temperature controller typically provides the firing rate signal.
AIN 0- (FIRING RATE)	J9-2	
AIN 1+ (FUTURE USE)	J9-3	Reserved for future use.
AIN 1- (FUTURE USE)	J9-4	
OUTPUTS		
AOUT 0+ (GAS FLOW)	J9-5	The 4 to 20 mA output signals indicate the gas and air mass flow measured by the SMARTFIRE™ Flow Controllers. For each signal: - 20 mA represents the full-scale flow of the respective Flow Controller. - 4 mA represents no flow.
AOUT 0- (GAS FLOW)	J9-6	
AOUT 1+ (AIR FLOW)	J9-7	Both outputs are isolated from the SMARTFIRE™ + 24 VDC supply and sources current.
AOUT 1- (AIR FLOW)	J9-8	
AOUT 2+ (GAS VALVE POSITION)	J9-9	The 4 to 20 mA output signals indicate the gas and air valve positions as measured by the SMARTFIRE™ Valve Actuators. For each signal: - 20 mA indicates a valve position of 100 degrees. - 4 mA indicates a valve position of 0 degrees.
AOUT 2- (GAS VALVE POSITION)	J9-10	
AOUT 3+ (AIR VALVE POSITION)	J9-11	The Valve Actuators currently open to a maximum position of 80 degrees. Each signal is isolated from the SMARTFIRE™ System's + 24 VDC supply and sources current.
AOUT 3- (AIR VALVE POSITION)	J9-12	

RS-232 Interface

Signal Name	Terminal	Signal Function
TX	J8-1	Reserved for future RS-232 SMARTFIRE™ monitoring, configuration, and diagnostic purposes.
RX	J8-2	
CTS	J8-3	
RTS	J8-4	
COM	J8-5	



Contact Esys for more information about this product:
 Esys® The Energy Control Company™
 4520 Stine Road, Ste 7
 Bakersfield, CA 93313
 (661) 833-1902

email: esys@esys.us
 website: <http://www.esys.us>



Electrical Installation Instructions

Power and Field Device Cable Terminations

Signal Name	Terminal	Signal Function
INPUT POWER		An isolated +24 VDC supply that provides 2 amps (or 50 watts) is required to power the SMARTFIRE™ System. A supply is provided as part of the SMARTFIRE™ Interface Panel and is pre-wired to these terminals.
+24 VDC	J1-1	
GND	J1-2	
GAS FLOW CONTROLLER		The SMARTFIRE™ field device power and communication signals are terminated on connectors J2 through J7 using four-wire shielded control cable (either Maxon P/N 59829 or Belden Cable #3086A). Connector J2 is provided as a spare connection for an optional User Display or connection to a telephone gateway (Maxon P/N 1055838) for remote monitoring.
+24 VDC	J7-1	
GND	J7-2	
DATA A	J7-3	
DATA B	J7-4	
AIR FLOW CONTROLLER		The color coding convention recommended for wiring all SMARTFIRE™ field devices when using Maxon control cable (P/N 59829) is: - +24 VDC: White/Orange - GND: Orange - Data A: White/Blue - Data B: Blue
+24 VDC	J6-1	
GND	J6-2	
DATA A	J6-3	
DATA B	J6-4	
GAS VALVE ACTUATOR		The color coding convention recommended for wiring all SMARTFIRE™ field devices when using Belden cable (# 3086A) is: - +24 VDC: Brown - GND: Blue - Data A: White - Data B: Black
+24 VDC	J5-1	
GND	J5-2	
DATA A	J5-3	
DATA B	J5-4	
AIR VALVE ACTUATOR		
+24 VDC	J4-1	
GND	J4-2	
DATA A	J4-3	
DATA B	J4-4	
DISPLAY		
+24 VDC	J3-1	
GND	J3-2	
DATA A	J3-3	
DATA B	J3-4	
SPARE		
+24 VDC	J2-1	
GND	J2-2	
DATA A	J2-3	
DATA B	J2-4	



Contact Esys for more information about this product:
 Esys® The Energy Control Company™
 4520 Stine Road, Ste 7
 Bakersfield, CA 93313
 (661) 833-1902

email: esys@esys.us
 website: <http://www.esys.us>



Start-up and Operation Instructions

Checkout before Start-up

After the SMARTFIRE™ System has been installed and **before power is applied**, follow the checkout procedure listed below:

1. Verify that all Maxon system numbers and burner model identifiers on the device labels are the same. Because all SMARTFIRE™ systems are preconfigured at the factory for a specific burner configuration, this verification is very important. It ensures that the proper components are installed.
2. Verify the Air Flow Controller and Air Valve Actuator are installed in the air pipetrain and the Gas Flow Controller and Gas Valve Actuator are installed in the gas pipetrain.
3. Verify the proper connection of the **SMARTFIRE™ READY** output contact to the start-up and running interlock of the User's burner management system. With no AC power applied to the SMARTFIRE™ Interface Panel, the **SMARTFIRE™ READY** output should provide an open contact to the burner management permissive circuit.
4. Verify that all other required terminations have been made at the Burner Brain.
5. Verify the connections and color coding convention on all control cable wiring at each SMARTFIRE™ field device and the Burner Brain.
6. On the Interface Panel with power off, measure the resistance between earth ground and each of the four signals wired to each field device: 24 VDC, GND, Data-A, and Data-B. The resistance should indicate an open circuit (i.e., a resistance value of several Mega-Ohms). If the resistance value does not indicate an open circuit, it is likely that there is a short circuit in the cabling between the field devices and the Burner Brain. Disconnect each cable and determine where the short circuit exists.
7. Perform all required prestart-up checkout procedures for the installed burner, pipetrain, and the burner management system.

Once these checks have been completed, the SMARTFIRE™ System is ready to operate in conjunction with the User's installed burner management system.

Start-up Procedure

During start-up, the SMARTFIRE™ System responds to commands supplied by the burner management system by moving its Air and Gas Valve Actuators to appropriate positions and closing several output contacts to acknowledge specific conditions such as "maximum combustion air" and "low fire start" conditions.

Note: The SMARTFIRE™ System does not replace, inhibit, or interfere with any of the safety functions provided by the User's flame relay or burner management system.

During the start-up sequence outlined below, if the User Display shows an alarm indication, reference the *Troubleshooting* section of these instructions (Page 7200-S-23) for appropriate action.

If the start-up sequence does not proceed as expected, check if the required SMARTFIRE™ input or output is powered and properly connected to the burner management system.

The following burner start-up procedure is driven by the User's burner management system:

1. Apply 120VAC power to the 24VDC Supply of the SMARTFIRE™ Interface Panel. After power is applied, the User Display reads, "System Initializing." All SMARTFIRE™ output contacts are opened while the System performs initialization and self-diagnostic tasks. The System will close the **SMARTFIRE™ READY** contact after approximately 20 seconds if all the following conditions are met:
 - The SMARTFIRE™ Flow Controllers and Valve Actuators are communicating properly;
 - A fuel leak test passes (i.e., fuel flow less than 1/20th the burner's flow at high fire);
 - Both Valve Actuators are in their pre-defined standby positions: and
 - The combustion-related data in the Burner Brain are correct.

When the System completes initialization successfully, the User Display reads "SMARTFIRE™ Ready ON, Waiting for Dr to Max" with no alarm conditions displayed. The SMARTFIRE™ System is now waiting for the burner management command to drive to a maximum air condition for purging.



Contact Esys for more information about this product:

Esys® The Energy Control Company™
4520 Stine Road, Ste 7
Bakersfield, CA 93313
(661) 833-1902

email: esys@esys.us

website: <http://www.esys.us>



Start-up and Operation Instructions

Before proceeding, press the Menu key of the User Display until the Burner Configuration Data screen is shown. Verify that the burner type and capacity data match the installed burner. **If the displayed data do not match the installed burner, discontinue the start-up and call Maxon.**

2. The burner management system energizes the SMARTFIRE™ **DRIVE TO MAX AIR** input relay. (In a mechanically controlled MICRO-RATIO® system, this burner management command would be used to drive open the MICRO-RATIO® valve motor.)
3. When the SMARTFIRE™ **DRIVE TO MAX** input is powered, the SMARTFIRE™ System prepares for a purge cycle and displays, "Driving to Max Air." The SMARTFIRE™ **ENABLE PURGE** output contact is closed if all the following conditions are satisfied:
 - Air Valve Actuator is opened to its full open position;
 - A fuel leak check is passed;
 - Communications are tested, and
 - Air flow greater than one-half of the burner's maximum required air flow is measured.

If the above conditions are satisfied, the SMARTFIRE™ System displays "Enable Purge ON, Waiting for Dr to Lightoff." It then waits for a low fire start command from the burner management system.
4. The burner management system applies to 120 VAC to the SMARTFIRE™ **DRIVE TO LIGHTOFF** input signal. (In a mechanically controlled MICRO-RATIO® system, this burner management command would be used to drive the MICRO-RATIO® valve to the minimum setting established by the mechanical linkage.)
5. When the SMARTFIRE™ **DRIVE TO LIGHTOFF** input signal is powered, the System prepares for burner management ignition trials. If all the following conditions are satisfied, within approximately 30 seconds, the SMARTFIRE™ **ENABLE IGNITION** output contact is closed:
 - Air flow control is enabled and the starting air flow is achieved;
 - Communications are tested; and
 - The Burner Brain verifies gas Valve Actuator starting position (nominally 5 degrees).

If the above conditions are satisfied, the SMARTFIRE™ display shows "Enable Ignition ON, Waiting for Main Valve ON." It then waits for the burner management system to prove pilot and begin main flame trials.

6. The burner management system energizes the burner spark transformer and proves a pilot flame.
7. The burner management system begins main flame trials. When this event occurs, the burner management system (typically using switches within the gas shut-off valve that close as the valve begins to open) energizes the SMARTFIRE™ **MAIN VALVE ON** relay input.
8. When the SMARTFIRE™ **MAIN VALVE ON** input is powered, the burner management system proves main flame while the SMARTFIRE™ System performs the following actions:
 - Closed loop control of fuel flow at the starting flow setpoint after a 10-second fuel modulation delay for the shut-off valve to fully open and the fuel sensor to read properly;
 - A 10-second firing rate delay timer is started which allows the burner management system to prove the main flame before the SMARTFIRE™ System can begin to adjust the burner's firing rate, and
 - A ratio check and a test for the SMARTFIRE™ **MODULATION ENABLE** input signal is started after the firing rate delay expires.
9. After the main flame establishment period (typically 10 to 15 seconds), the burner management system energizes the SMARTFIRE™ **MODULATION ENABLE** relay input.
10. When the SMARTFIRE™ **MODULATION ENABLE** input is powered, SMARTFIRE™ begins to adjust the burner's firing rate based on the SMARTFIRE™ **FIRING RATE** input, a 4-20 mA signal from the User's temperature or process controller. SMARTFIRE™ translates the Firing Rate signal into air and fuel flow setpoints that are determined by the Maxon burner model being used in the application. These setpoints are transmitted to their respective Mass Flow Controllers, which, in turn, modulate the position of their respective Valve Actuator through digital position commands sent over the control network.



Contact Esys for more information about this product:
 Esys® The Energy Control Company™
 4520 Stine Road, Ste 7
 Bakersfield, CA 93313
 (661) 833-1902

email: esys@esys.us
 website: <http://www.esys.us>



Start-up and Operation Instructions

After the burner is lit, the SMARTFIRE™ System continuously tests for the following unsafe operating conditions:

- An incorrect ratio;
- Loss of communication to either Fuel or Air Flow Controller;
- Corrupted Burner Brain memory;
- Improper Burner Brain program execution that tests for the three previous fault conditions; and
- Fuel or air flow measurements that exceed the range of the sensor.

If the SMARTFIRE™ System detects any of these fault conditions, it initiates a combustion system shutdown by opening the **SMARTFIRE™ READY** contact that is wired to the burner management system's running interlocks. When the interlock string is opened, the burner management system de-energizes the main gas shut-off valves. A SMARTFIRE™ reset must be performed to allow a re-start. This can be accomplished through the display or by momentarily powering the alarm reset input or repowering the SMARTFIRE™ System.

SMARTFIRE™ will return to the beginning of its start-up sequence if the burner management system initiated the shutdown event or if the main gas shut-off valve is closed at anytime. SMARTFIRE™ detects a closed main gas shut-off valve through its **MAIN VALVE ON** input signal.

Checkout after Start-up

Note: After the burner is running at minimum fire, perform the following checkout procedures to ensure safe operation.

1. Verify that the **SMARTFIRE™ READY** output (used by the burner management system as a burner interlock) is operational by removing 120VAC power to the SMARTFIRE™ System. The burner should shut-off when this test is performed.
2. Restart the burner. If process temperature limits will not be exceeded, place the User's temperature controller in manual mode and ramp the burner to approximately 25-50% capacity. After the burner reaches the requested firing rate, validate SMARTFIRE™ flow readings by measuring air and gas pressures at the taps typically provided at the burner. Using the burner's flow-versus-pressure curves, verify that the flows calculated using pressure are within 10% of the SMARTFIRE™ flow readings available on the User Display.
3. If process temperature limits will not be exceeded, ramp the burner to maximum capacity and check for any fuel or air flow "high limit" alarms (i.e., insufficient gas pressure or combustion blower capacity).

If an air flow limit is reached, check the specifications of the installed combustion blower and determine if the blower is undersized.

If a fuel high limit is reached, increase the gas regulator pressure; reset the alarms with the User Display (refer to the *User Display Functions* section on the following page) and verify the high limit alarm condition has been eliminated.

With the burner at maximum capacity, adjust the gas regulator pressure until the gas valve actuator position is between 50 and 60 degrees. If the blower is undersized or the available gas pressure is not adequate to reach the desired capacity, refer to the *Maxon Field Configuration* section (page 7200-S-21).
4. Ramp the burner back down to minimum fire and check for an air or fuel "low limit" alarm (i.e., the gas/air pressure may be too high or the installed valve characteristics due to piping hydraulics may limit burner turndown). Readjust the gas pressure regulator, reset the alarms with the User Display and repeat Steps 3 and 4.

If both maximum and minimum burner capacities cannot be achieved due to pressure limitations or pressure losses in the piping, refer to the *Maxon Field Configuration* section (Page 7200-S-21) to permanently modify the application's capacity limits. If the application capacity limits are not modified, the SMARTFIRE™ System will automatically limit the maximum and minimum capacities and run with the proper ratio. However, a "low limit" or "high limit" condition will be indicated until power is cycled or the alarms are reset.
5. After adjusting the gas pressure, turn the burner off and cycle power to SMARTFIRE™. This resets the flow checking function in the Burner Brain. This continuous, on-line checking function tests for reasonable flow measurements that are critical to proper operation of a burner system and detection of flow sensor failures.

Start-up and Operation Instructions

6. For some applications, on-site adjustment of the air/fuel ratio is necessary to optimize emissions or fuel efficiency. Although the SMARTFIRE™ System delivers high-precision, turnkey ratio control performance, adjustment of the air/fuel ratio is sometimes required due to variations in gas composition or piping configurations that cause errors in flow measurements. This adjustment procedure can be accomplished by source testing the burner system while trimming (in 1% steps) the entire air/fuel ratio curve using the User Display. Refer to the *User Display Functions* section on page 7200-S-20 for instructions.
7. For applications that must optimize emissions or fuel efficiency over a significant turndown, the air/fuel ratio can also be trimmed in twenty 5% segments that cover 100% of the burner's capacity. Maxon-trained personnel must perform this adjustment capability using a PC and SMARTFIRE™ commissioning software.

User Display Functions

The SMARTFIRE™ User Display is used to adjust air/fuel ratio, view start-up status, System performance, flow, alarm data, view and reset flow totals, perform valve diagnostics, and reset alarm and shutdown conditions. These functions can be easily accessed using the display's MENU and BACK (or ESCAPE) keys.

The table on the following page summarizes all User Display functions and is organized in the order that menu items are accessed using the MENU and ESCAPE keys. The up and down ARROW keys are used to scroll down sub-menus and increase or decrease specific adjustable parameters such as air/fuel ratio.



Contact Esys for more information about this product:
Esys® The Energy Control Company™
4520 Stine Road, Ste 7
Bakersfield, CA 93313
(661) 833-1902

email: esys@esys.us
website: <http://www.esys.us>



Start-up and Operation Instructions

User Display Functions

User Display Menu Item (See Note 1)	Sub-Menus (See Note 2)	Menu and Sub-Menu Descriptions
SYSTEM STATUS	Yes	View system data and alarm status. During burner start-up process (indicated by "Start-up" message in upper right hand corner of User Display), view SMARTFIRE™ start-up actions, inputs needed to proceed, and alarms. After start-up process (indicated by "Control ON" message), view heat demand/output and alarm status. View firing rate, ratio, air and fuel flows, flow errors, and air/fuel valve positions using sub-menus.
RESET LATCHED ALARMS	None	Press [Enter] key to reset "latched" alarm conditions. These alarms remain indicated until this display function is executed or until SMARTFIRE™ input power is cycled. Latched alarms include system shutdowns, flow check alarms and high/low demand limit alarms.
RESET DEMAND LIMITS	None	Press [Enter] key to reset demand limits. These limits are set when the fuel or air flow for the firing rate (demanded by the User's temperature controller) cannot be achieved. When a limit is reached, the SMARTFIRE™ System adjusts its maximum or minimum firing rate to a level that permits proper ratio control.
CONFIGURATION DATA	Yes	View pre-programmed combustion-specific data: maximum/minimum fuel flow and the burner model of the stored air/fuel ratio data. Sub-menus include software version numbers for each installed SMARTFIRE™ component.
ADJUST AIR/FUEL RATIO	None	Adjust the installed air/fuel ratio curve leaner (increase ratio) or richer (decrease ratio) in 1% steps by pressing the up or down ARROW keys. This function can be performed when the burner is off or on. If the burner is on, this function will only be executed if the SMARTFIRE™ System is controlling at the requested firing rate setpoint.
FLOW TOTAL	Yes	View fuel flow total. Sub-menus include viewing total hours of burner operation, fuel (and oxygen, if applicable) flow total, and a reset function for each total.
SHUTDOWN TOTAL	Yes	View number of burner shutdowns caused by SMARTFIRE™ (i.e., removal of SMARTFIRE™ READY output after burner is lit). Sub-menu includes total system shutdowns for external causes and a reset function for each total.
VALVE CALIBRATION	Yes	Perform air valve actuator calibration. Sub-menus include a valve actuator calibration check and open-close position test. When any of these functions are executed, all other key functions are inhibited until the command is completed and the [Enter] key must be pressed to continue.
FLOW CHECK ENABLE/DISABLE	Yes	Enable or disable the continuous on-line flow check. Sub-menus include flow check results (in degrees of valve position change and flow range), flow check alarm status, and flow check reset. The flow check is also reset when SMARTFIRE™ power is cycled off and on. The air and gas flow check will produce an alarm condition if the valve position for a given flow changes an amount greater than the selected threshold.
PRODUCT SUPPORT	None	View Maxon toll-free number (1-800-652-3553) for product support.

Note 1: Press [Menu] key to move down menu. Press [Back] (or [Escape]) to move up menu list.

Note 2: Press arrow up/arrow down keys to move up and down sub-menus.



Contact Esys for more information about this product:

Esys® The Energy Control Company™
4520 Stine Road, Ste 7
Bakersfield, CA 93313
(661) 833-1902

email: esys@esys.us

website: <http://www.esys.us>



Start-up and Operation Instructions

Maxon Field Configuration

Using a PC connected to the SMARTFIRE™ control network and SMARTFIRE™ commissioning software, Maxon field personnel can perform the following field configuration functions:

- For applications that require on-site optimization of emissions or fuel efficiency over a wide turndown, the air/fuel ratio can be adjusted in twenty 5% segments of burner firing capacity. The adjustments can be made leaner or richer in 1% steps.
- Modify maximum, minimum, and starting firing rates due to fuel pressure limitations, undersized combustion blower, underestimated pressure losses in piping.
- Modify starting fuel valve position for applications with long piping runs between the shut-off valve and the burner and have a burner management system with a very short main flame-establishment period.

See the *Product Support* section on page 7200-S-22 for information on Maxon SMARTFIRE™ Technical Support.

Local and Remote Monitoring

Local monitoring of the SMARTFIRE™ System can be accomplished by connecting a User's DCS (Distributed Control System) or data acquisition system. This monitoring may be required to meet local environmental regulations that mandate a record of air/fuel ratio performance data in place of costly periodic or continuous emissions monitoring. Local SMARTFIRE™ monitoring may also be useful to help determine the cause of a burner shutdown.

The most straightforward method for local monitoring is to connect the User's monitoring system to the two alarm contacts and the four isolated 4-20 mA outputs that represent fuel and air flow and fuel and air valve position.

Remote diagnostic support by Maxon field personnel can also be performed with an optional SMARTFIRE™ telephone gateway (Maxon P/N 1055838) and a local telephone line. This remote monitoring option allows trained personnel to log diagnostic control data and help the customer diagnose a problem without an on-site service call.



Maxon SMARTFIRE™ Telephone Gateway



Contact Esys for more information about this product:
Esys® The Energy Control Company™
4520 Stine Road, Ste 7
Bakersfield, CA 93313
(661) 833-1902

email: esys@esys.us
website: <http://www.esys.us>



Maintenance and Product Support

Maintenance

The SMARTFIRE™ System continuously monitors its components for proper operation and alarms when failures or maintenance issues arise. Maxon recommends a minimum monthly check for alarm conditions that are indicated by SMARTFIRE™ alarm contacts and by alarm messages on the User Interface Display.

When alarms occur, the user should follow the *Troubleshooting* section of these instructions (Page 7200-S-23) to determine if any maintenance action is required. For example, if a Flow Test or Flow Limit Alarm occurs, a flow limitation or sensing problem may exist that requires cleaning of the combustion fan filter, removing debris in the flow conditioning screens, or cleaning contaminants on the flow sensor probe.

Maxon also recommends the calibration of the SMARTFIRE™ Air and Fuel Flow Controllers be verified at least every 5 years. This verification can be accomplished in the field using the sensor validation procedure described in the *Start-up and Operation* section of these instructions (Page 7200-S-16 to 21). For a more precise evaluation of sensor calibration, the sensor probe assemblies can be removed from their flow bodies and shipped to Maxon Corporation in Muncie, Indiana, for testing.

All maintenance work performed on the Fuel or Air Flow Controllers must be performed with the System turned off. Cleaning of the flow sensor probes can be done with any solvent material suitable for stainless steel. However, care should be taken not to bend the two small sensing probes. Revalidation of any flow sensor that has been cleaned or removed from its flow body is required before re-commissioning the combustion system.

If the SMARTFIRE™ System is applied in combustion systems with minimal combustion air filtering or with fuel gas contaminants, the SMARTFIRE™ alarm contacts should be monitored by the plant or process DCS system to alert personnel of improper operation and possible maintenance issues.

Product Support

Maxon Corporation provides 24-hour telephone support for all SMARTFIRE™ customers. If you have a question that relates to the installation, operation, or maintenance of the SMARTFIRE™ System, please call 800-652-3553 (within the United States or Canada) and your call will be answered immediately or returned as soon as possible.



Contact Esys for more information about this product:
Esys® The Energy Control Company™
4520 Stine Road, Ste 7
Bakersfield, CA 93313
(661) 833-1902

email: esys@esys.us
website: <http://www.esys.us>



Troubleshooting

Problem/User Display Alarm	Description/Possible Cause	Response/Solution
"A/F RATIO LEAN ALARM"	- Flow control loop may be momentarily overshooting its setpoint, - one of the Flow Controllers is not measuring flow correctly, or - a supply (or chamber) pressure may have suddenly changed	If alarm persists at a constant firing rate, re-validate flow readings according to the procedures in the "Checkout after Startup" Section of the Start-up and Operation Instructions (page 7200-S-18).
"A/F RATIO RICH ALARM" (Note 1)	- Flow control loop may be momentarily overshooting its setpoint, - one of the Flow Controllers is not measuring flow correctly, or - a supply (or chamber) pressure may have suddenly changed	If alarm persists at a constant firing rate, re-validate flow readings according to the procedures in the "Checkout after Startup" Section of the Start-up and Operation Instructions (page 7200-S-18). If the SMARTFIRE™ System shuts down the burner, reset alarm with the User Display or external reset input.
"AIR (OR FUEL) ACT ADC ALARM"	Failed actuator control electronics or actuator cannot achieve required position	Check for debris, flange or gasket material interfering with valve movement. If no blockage is found and alarm still exists after cycling power to the SMARTFIRE system, replace actuator.
"AIR (OR FUEL) ACT 24V ALARM"	Out-of-range actuator DC supply voltage	Check for heavily loaded 24VDC supply, a failed supply, or whether an actuator cable run is too long.
"AIR (OR FUEL) ACT CAL ALARM"	Replacement actuator is not calibrated after being installed on a valve	Re-calibrate the actuator with the User Display.
"AIR (OR FUEL) ACT COMM ALARM"	Burner Brain cannot communicate with a Valve Actuator	Check for an intermittent control cable connection or replace actuator.
"AIR (OR FUEL) ACT POS1-4 ALARM"	An actuator cannot achieve the required position setpoint	Check if there is debris in the valve that could inhibit valve movement and use the User Display valve diagnostics to move the Valve Actuator open and close. DO NOT try to move the valve manually with power applied. The position of the valve can be viewed using the markings on the actuator-valve coupling.
"AIR (OR FUEL) ACT RESET ALARM"	Improper software execution and/or control electronics failure	Check if the actuator is near a large electrical noise source and move noise source if possible. If alarm condition reoccurs, replace actuator.
"AIR (OR FUEL) ACT TEMP ALARM"	Out-of-specification ambient temperature or an actuator control electronics failure	Check temperature of actuator's enclosure and remove heat source or promote circulation if too hot. If temperature is not near maximum rating, replace actuator.
"AIR (OR FUEL) FLOW ADC ALARM"	Failed flow control electronics	Cycle power to SMARTFIRE™ System, and if alarm still occurs, replace Flow Controller.
"AIR (OR FUEL) FLOW COMM ALARM" (Note 1)	Burner Brain cannot communicate with a Flow Controller	Check for an intermittent control cable connection or replace Flow Controller.
"AIR (OR FUEL) PROBE ALARM"	Flow controller is measuring incorrect flows	Recycle SMARTFIRE™ power and replace Flow Controller if alarm persists.

Note 1: Specific alarm conditions, as indicated in Troubleshooting table above, will lead to a shutdown condition which opens the SMARTFIRE Ready permissive contact and closes the Alarm #1 contact.



Contact Esys for more information about this product:

Esys® The Energy Control Company™
4520 Stine Road, Ste 7
Bakersfield, CA 93313
(661) 833-1902

email: esys@esys.us
website: <http://www.esys.us>



Troubleshooting *(Continued)*

Problem/User Display Alarm	Description/Possible Cause	Response/Solution
"AIR (OR FUEL) FLOW RANGE ALARM" <i>(Note 1)</i>	Flow Controller's measurement range is exceeded during closed-loop air/fuel ratio control or moisture/wet contaminants on the flow sensing elements If the alarm is for Fuel: Flow Controller detected fuel flow during burner startup before the main gas shut-off valves opened	Inspect the flow sensor probe for moisture/contaminants, clean if necessary, and eliminate moisture/contamination source if possible. Re-validate flow readings as per the procedures in the "Checkout after Startup" Section of the Start-up and Operation Instructions (page 7200-S-18). If alarm is for fuel, check for premature opening of the main gas shut-off valve before the SMARTFIRE™ Main Valve ON input is energized and check the gas shut-off valves for leakage. If re-validation of flow readings fail or alarm persists, replace Flow Controller
"AIR (OR FUEL) FLOW RESET ALARM"	Improper software execution and/or flow control electronics failure	Check if Flow Controller is near a large electrical noise source and move noise source if possible. If alarm condition reoccurs, replace Flow Controller.
"AIR (OR FUEL) FLOW TEMP ALARM"	Out-of-specification ambient temperature or flow control electronics failure	Check temperature of Flow Controller's enclosure and remove heat source or promote circulation if too hot. If temperature is not near maximum rating, replace Flow Controller.
"AIR (OR FUEL) FLOW TEST ALARM" <i>(Note 2)</i>	Valve position change for a given flow exceeds the selected threshold. This alarm can be caused by changes in fuel or air supply pressures, blocked combustion air filter, Flow Controller failures, large changes in chamber back pressure, moisture/contamination on flow sensing elements	Inspect the combustion fan filter and clean if necessary. Inspect flow sensor probe for moisture/contaminants, clean if necessary, and eliminate moisture/contamination source if possible. Re-validate flow readings as per the procedures in the "Checkout after Startup" Section of the Start-up and Operation Instructions (page 7200-S-18) and reset the alarm with the User Display. If re-validation of flow readings fail, replace Flow Controller if alarm reoccurs.
"AIR (OR FUEL) HI LIMIT ALARM"	Lack of combustion air, low gas pressure, or a Flow Controller failure	Check combustion air filter for blockage, increase gas pressure, or increase air supply source. Reset alarm and demand limits with the User Display or cycle SMARTFIRE™ power. If alarm reoccurs, re-validate flow readings according to the procedures in the "Checkout after Startup" Section of the Start-up and Operation Instructions (page 7200-S-18). If validation fails, replace Flow Controller.
"AIR (OR FUEL) LO LIMIT ALARM"	Oversized combustion blower, high gas pressure, or a Flow Controller failure	Decrease gas or air pressure. Reset alarm with the User Display or cycle SMARTFIRE™ power. If alarm reoccurs, re-validate flow readings according to the procedure in the "Checkout after Startup" Section of the Start-up and Operation Instructions (page 7200-S-18). If validation fails, replace Flow Controller.

Note 1: Specific alarm conditions, as indicated in Troubleshooting table above, will lead to a shutdown condition which opens the SMARTFIRE Ready permissive contact and closes the Alarm #1 contact.

Note 2: An air or fuel flow test alarm will close the Alarm #1 contact but will NOT shut down the system (unless the customer uses this contact to cause a system shutdown with an additional external relay connected as a combustion safety running interlock).



Contact Esys for more information about this product:

Esys® The Energy Control Company™

4520 Stine Road, Ste 7

Bakersfield, CA 93313

(661) 833-1902

email: esys@esys.us

website: <http://www.esys.us>



Troubleshooting (Continued)

Problem/User Display Alarm	Description/Possible Cause	Response/Solution
"AMBIENT TEMP ALARM"	Out-of-specification Burner Brain ambient temperature or a control electronics failure	Check temperature close to Burner Brain and remove heat source or promote circulation if too hot. Provide external heat source if too cold. If temperature is not near maximum or minimum rating, replace Burner Brain.
"BRAIN ADC ALARM"	Burner Brain electronic analog-to-digital conversion (ADC) hardware failure	Re-power system and if alarm persists, replace Burner Brain.
"CHECKER COMM ALARM"	Burner Brain cannot communicate with the Flow Checker hardware within the Burner Brain	Check for a short on Data-A or Data-B of the field device control cable or replace the Burner Brain.
"CONTROL DISABLED"	Select A and Select B inputs are both energized after the burner is lit	Remove power to both inputs unless using this function during a switch to a propane/air mixture in place of natural gas.
"HIGH AIR FLOW ALARM"	During startup, if the air valve is closed and the air flow is too high to light the burner, a high air flow alarm is indicated	Re-validate air flow reading (at purge condition). If reading is valid, increase the lightoff and minimum firing rate or reduce air pressure. If air flow validation fails, replace Air Flow Controller.
"HIGH FUEL FLOW ALARM"	Gas shut-off valve leak or a Gas Flow Controller failure	Check if fuel shut-off valves are properly functioning. Reset alarm with the User Display or cycle SMARTFIRE™ power. If alarm reoccurs after checking shut-off valves, replace Gas Flow Controller.
"LOW AIR FLOW ALARM"	Lack of combustion air or a failed Air Flow Controller	Check if combustion air blower is on. Check if any blockages exist that could restrict air flow. Check air pressures at burner. If blower is powered, no blockages exist, and air pressure at burner taps is reasonable, replace Air Flow Controller.
"MEMORY ERROR ALARM" <i>(Note 1)</i>	Burner Brain memory is corrupted	Replace Burner Brain.
"SUPPLY CURRENT ALARM"	SMARTFIRE™ 24VDC supply is overloaded	With the burner off, disconnect each field device one at a time to determine the unit drawing too much current.
"WATCHDOG (or SYSTEM) RESET ALARM" <i>(Note 1)</i>	Improper software execution and/or Burner Brain electronics failure	Re-power system and if alarm persists, replace Burner Brain.

Note 1: Specific alarm conditions, as indicated in Troubleshooting table above, will lead to a shutdown condition which opens the SMARTFIRE Ready permissive contact and closes the Alarm #1 contact.

Note 2: An air or fuel flow test alarm will close the Alarm #1 contact but will NOT shut down the system (unless the customer uses this contact to cause a system shutdown with an additional external relay connected as a combustion safety running interlock).



Contact Esys for more information about this product:
 Esys® The Energy Control Company™
 4520 Stine Road, Ste 7
 Bakersfield, CA 93313
 (661) 833-1902

email: esys@esys.us
 website: <http://www.esys.us>



SMARTFIRE™ Actuator Field Replacement Instructions

Actuator Removal

1. Verify that the SMARTFIRE™/Burner System is completely shut down and that the gas shut-off valve is closed. DO NOT try to move the valve manually with power on.
2. Remove the actuator access cover using an M3 Allen wrench, and verify that there is no power to the unit. The 3 lights (power, status, and diagnostic LEDs) should not be lit if power is off.
3. Record the wire color code sequence and then disconnect the four lead wires from the terminal block. Disconnect any conduit fittings.
4. Loosen the clamp collar set screw with a 3/16" Allen wrench.
5. Remove the four M6x1x18mm socket head cap screws connecting the actuator to the valve adapter with an M5 Allen wrench.
6. Remove the actuator by holding the actuator housing and pulling the actuator along the shaft axis, away from the valve.
7. **IMPORTANT: Move the valve to a fully closed position using the hole below the clamp collar.**

Actuator Reinstallation

1. Inspect the actuator shaft and verify that the 1/8" square 1/2" long key is completely seated in the shaft slot.
2. **IMPORTANT: Verify that the clamp collar is loose and the valve is in a fully closed position.** The collar should have the screw head on the left when looking at the clamp with the collar at the top.
3. Align the shaft key with the slot in the coupling and insert the shaft into the coupling. Turn the actuator housing as needed so the alignment pin on the actuator is aligned with the valve adapter hole (closest to the open face of the valve adapter).

Note: Older units may have an alignment bushing in place of a dowel pin.

If you have an older unit, remove the dowel pin from the replacement actuator with a pair of pliers and proceed with installation. To confirm proper orientation of the actuator to the adapter, verify that the pinhole is over the adapter opening prior to bolting in place.

4. The parts are a clearance fit but should slip together with little force. Apply pressure until the actuator is flat against the adapter. (DO NOT apply excessive force — if the valve adapter and actuator do not mate together, recheck that the clamp is loose and the key is pressed to the bottom of the key slot.) Verify that the actuator is seated flush to the valve adapter. Install the four M6x1x18 mm socket head cap screws and torque to 18 in-lbs. with an M4 Allen wrench.
5. Verify that the clamp collar is seated flush against the coupling shoulder. Tighten the socket head cap screw with a 3/16" Allen wrench and torque to 110 in-lbs.
6. Remove the access cover using an M4 Allen wrench and make the necessary water-tight electrical conduit connection. Connect the four wires to the terminal strip per the original color code sequence. Connect the shield wire to the terminal strip, keeping it as short as possible.
7. Apply power to the SMARTFIRE™ System and, using the User Interface Display, verify that the actuator has power and is communicating with the Burner Brain.
8. Reinstall the access cover and torque the four fasteners to 18 in-lbs. using an M3 Allen wrench.
9. Run the actuator calibration function from the User Interface Display main menu.

See next page for schematic of typical Valve/Actuator assemblies.



Contact Esys for more information about this product:
 Esys® The Energy Control Company™
 4520 Stine Road, Ste 7
 Bakersfield, CA 93313
 (661) 833-1902

email: esys@esys.us
 website: <http://www.esys.us>



SMARTFIRE™ Actuator Field Replacement Instructions

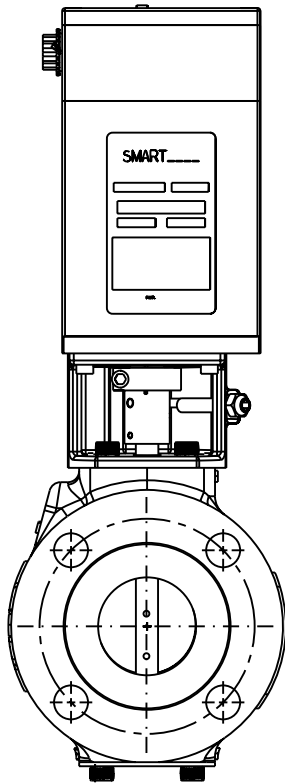

**Typical Valve/Actuator Assembly
1" through 4" valves**

(2" valve shown)

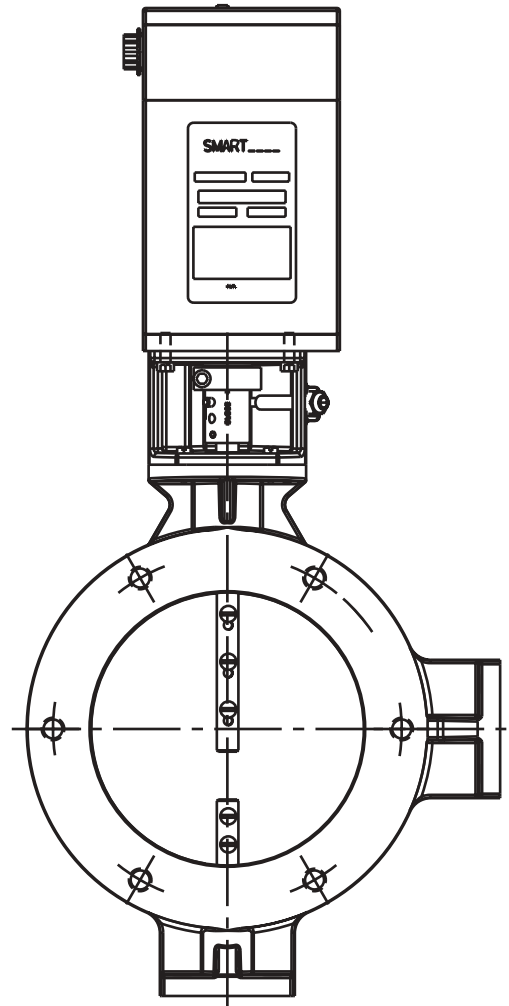

**Typical Valve/Actuator Assembly
6" through 16" valves**

(6" valve shown)



Contact Esys for more information about this product:
Esys® The Energy Control Company™
4520 Stine Road, Ste 7
Bakersfield, CA 93313
(661) 833-1902

email: esys@esys.us
website: <http://www.esys.us>

