

Installation Instructions

1. **Read complete instructions** before proceeding and do not discard packing materials until any/all loose items are located. Also, make sure that the installation of the Maxon valves will be in compliance with all applicable governmental, insurance and/or agency requirements or codes, such as NFPA-70, National Electric Code, CSA C22.1, Canadian Electric Code, etc.
2. **General considerations:**
 - A. Prior to shipment, each valve is operated electrically and cycled at rated and 1-1/2 rated pressure while being leak tested. **Every Maxon valve is operationally tested and meets the requirements of ANSI B16.104 Class VI Seat Leakage.**
 - B. **Inspect your valve** for any shipping damage. Contact Maxon Corporation with the valve's serial number (printed on the valve's nameplate) for replacement and/or repair parts.
 - C. **Read the nameplate on your valve.** This gives the maximum pressure, temperature limitation, voltage requirements and service conditions of your specific valve. **DO NOT exceed nameplate ratings.**
 - D. **Select mounting location carefully.** Your Maxon valve is designed to operate for many years if installed in a location that is cool, clean and dry.
3. **Pipe the valve** in the direction of the flow arrow [3] on the valve body. The Maxon valve body can shut off flow in one direction only.
 - A. **Remove all thread and flange protectors** before installing valve in your service line.

- B. **Teflon tape** acts as a lubricant and greatly reduces the pipe wrench turning force required to seal the threads.

Take care not to overtighten threads as this can damage the valve.

- C. **Good piping practice** dictates that piping be independently supported, so that valve bodies are not placed in a bind. In addition, large valves may require support.
- D. **Clean pipe lines** of foreign materials before installing valve into line.

For new installations, a gas filter or strainer shall be installed in the fuel gas piping to protect the downstream safety shut-off valves.

per NFPA 86-4-2.4.3 (1999)
 NFPA 86C-4-2.4.3 (1999)
 NFPA 86D-4-2.4-3 (1999)

If normal inlet pressure to the fuel pressure regulator immediately upstream from the valve exceeds the valve's pressure rating, a relief valve shall be provided and it shall be vented to a safe location.

per NFPA 86-5-7.1.7 (1999)
 NFPA 86C-5-7.1.7 (1999)
 NFPA 86D-5-7.1.7 (1999)

- E. **Mount valve** so that open/shut window indicator [1] will be visible to your operating personnel. **The open/shut window indicator should never face downward.** With Maxon electro-mechanical top assemblies, the motor access side plate [2] should always be vertical to the ground. Valves are usually installed in horizontal piping; however, other

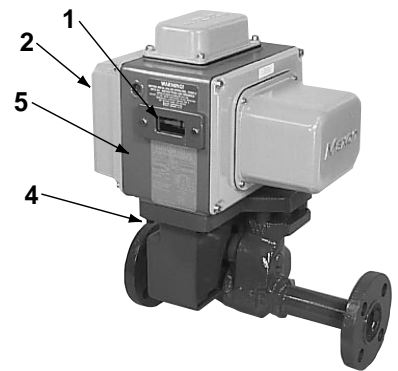
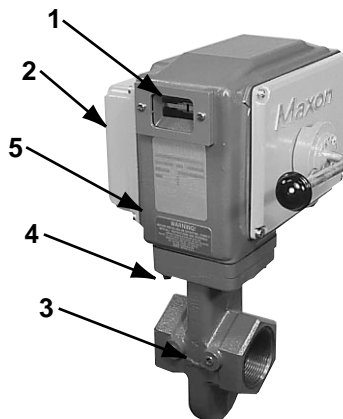
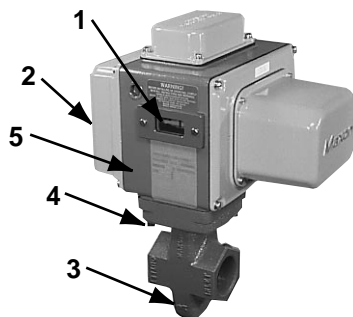

Contact Esys for more information about this product:
 Esys® The Energy Control Company™
 4520 Stine Road, Ste 7
 Bakersfield, CA 93313
 (661) 833-1902

email: esys@esys.us
 website: <http://www.esys.us>



Installation Instructions (cont'd.)

orientations are acceptable, subject to the above limitations. The top assemblies of all Maxon valves are field rotatable to allow installations involving conflicts with these mounting restrictions.

- F. Main system shut-off** should always use a manual leak-tight upstream fuel cock.
- G. Time lag** between valve action and fluid flow (or flame response) is reduced if valve is located near the burner (or outlet).
- 4. Wire the valve** in accordance with **all** applicable codes and standards. Supply voltages must agree with valve's nameplate voltage within -15%/+10% AC for proper operation. For electrical wiring schematics, refer to appropriate Maxon catalog literature and/or the wiring schematic diagram affixed inside your valve's access cover plate or in the terminal block cover housing.
- A. The Maxon valve must be electrically interlocked** with your safety-limit devices in accordance with all applicable codes, standards, and the authority having jurisdiction over the safety requirements for your overall system installation. Normally, Maxon valves are electrically wired in series with all of your safety-limit devices. Therefore, any one device can cause the valve to react. Each valve was production tested when manufactured. If it now appears inoperative, make sure it is being powered properly from and through your control circuit.

- B. Maintain integrity of Maxon top assembly enclosure** by using dust and water-tight electrical connectors. Use cable-sealing grips and strain-relief loops for any cord or cable. Use internal sealing materials on all conduit connections. Moisture can have a harmful effect on valve internals if permitted to enter through wiring connectors. Make sure that all access cover plates are in place and securely fastened. All cover screws should be tightened using an alternate cross corner tightening pattern to the values shown below.

Cover	Torque (in-lbs)
#10-24 Operator Cover	25
.25"-20 All other access covers	50
.25"-20 Extended Access Cover Plate	96

While all covers are torqued at time of production testing, torque should be rechecked periodically to ensure adequate sealing protection.

- 5. Pre-operational exercising:**
Prior to initial fluid flow start-up and with upstream manual cock still closed, operate the valve electrically for 10-15 cycles. This not only provides an electrical check, but also wipes valve body disc and seat free of accumulated foreign matter.



Contact Esys for more information about this product:
 Esys® The Energy Control Company™
 4520 Stine Road, Ste 7
 Bakersfield, CA 93313
 (661) 833-1902

email: esys@esys.us
 website: <http://www.esys.us>



Installation Instructions (cont'd.)

Top Assembly Rotation

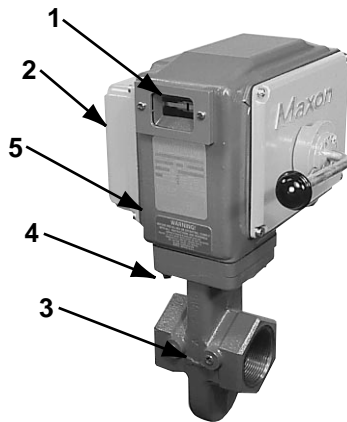

Series 808NI-CP

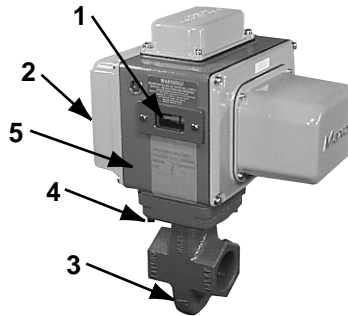

Series 5000NI

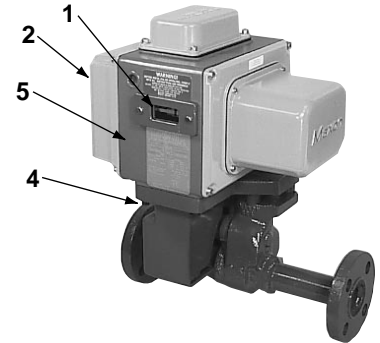

Series 4760NI
with socket welded
nipples & flanges

Maxon valves can and should be ordered in a configuration compatible with planned piping, but if open/shut indicator window is not visible and/or valve orientation is not proper, the top assembly can be rotated in 90° increments around the valve body centerline axis by the following procedure:

1. **Shut off all electrical power** and close off upstream manual cock.
2. **Remove wiring access cover plate [2]** and disconnect power lead wires. (Tag carefully for later re-assembly.)
3. **Remove conduit and electrical leads.**
4. **Note physical position** of any signal switch actuator wands on auxiliary signal switches (see switch arrangement sketch).
5. Unscrew the two body bolts [4] screwed up from the bottom to 1/4 inch. **DO NOT** completely remove. These bolts secure the valve body [3] to the valve's top assembly housing [5].
6. **Gently lift the top assembly [5] (not more than 1/4" in height)**; just enough to break the seal between the valve body assembly and the rubber gasket adhering to the bottom of the top housing.

WARNING: LIFTING TOO FAR MAY DISLodge SOME SMALL PARTS INSIDE THE TOP HOUSING, REQUIRING COMPLEX RE-ASSEMBLY AND RETESTING BY TRAINED FACTORY PERSONNEL.

Auxiliary Switch Arrangement

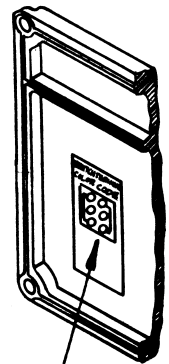
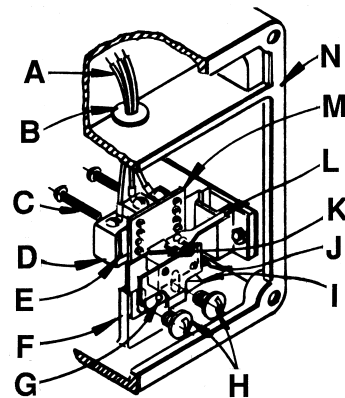

Wiring Diagram

- | | |
|--|---------------------------------------|
| A- Number Coded Wires | H- Mounting Screws |
| B- Rubber Grommet | I- Spring Retainer Extension |
| C- Mounting Screws | J- Switch Wand |
| D- Normal (de-energized) Position Switch | K- Actual (energized) Position Switch |
| E- Insulating Barrier | L- Switch Wand |
| F- Bracket Mounting Pad | M- Switch Mounting Bracket |
| G- Drive Pin & Locating Hole | N- Gasket |



Contact Esys for more information about this product:
 Esys® The Energy Control Company™
 4520 Stine Road, Ste 7
 Bakersfield, CA 93313
 (661) 833-1902

email: esys@esys.us
 website: <http://www.esys.us>



Installation Instructions (cont'd.)

Top Assembly Rotation (cont'd.)

7. Remove the two body bolts [4] screwed up from the bottom (were partially unscrewed in step 5).
8. Carefully rotate top assembly to the desired position in a plane parallel to the top of the valve body casting. Rotate the top housing about 30° beyond this position, and then rotate it back. Reposition the top housing back down onto the valve body casting. This should align the open/shut indicator with its window and provide proper alignment of the internal mechanism.
9. Realign holes in valve body casting with the corresponding tapped holes in the bottom of the top assembly housing. Be sure the gasket is still in place between the body and top housing.
10. Reinsert the body bolts up from the bottom through the body and carefully engage threads of the top assembly. Tighten securely.

Cover	Torque (in-lbs)
#10-24 Operator Cover	25
.25"-20 All other access covers	50
.25"-20 Extended Access Cover Plate	96

11. Reconnect conduit, electrical leads, and all pneumatic lines, then check that signal switch wands are properly positioned and that open/shut indicator moves freely. **Failure to correct any such misalignment can result in extensive damage to the internal mechanism of your valve.**
12. Energize valve and cycle several times from closed to full open position. Also electrically trip the valve in a partially opened position to prove valve operates properly.
13. Replace and secure side cover access plate and place valve in service.

Alternate Top Assembly Positions

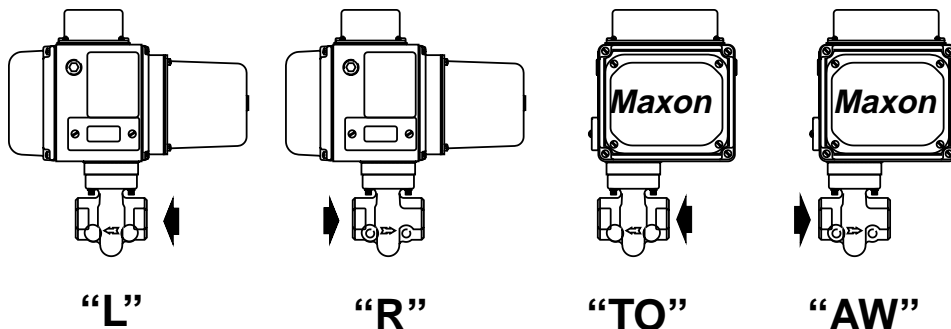

Four top assembly positions are available for most Maxon valves. When looking at the open/shut window indicator of an electro-mechanical valve assembly, the motor (for motorized version), or the operating handle (for manual version), will be on the right side of the top assembly. The valve body is on the bottom. From this view, the unidirectional valve

body and the arrow on the valve body casting points in direction of fluid flow: to the right (position "R"), to the left (position "L"), towards you (position "TO") or away from you (position "AW"). With smaller size swinging gate valve bodies, only position "R" and position "TO" may be used.



Contact Esys for more information about this product:
 Esys® The Energy Control Company™
 4520 Stine Road, Ste 7
 Bakersfield, CA 93313
 (661) 833-1902

email: esys@esys.us
 website: <http://www.esys.us>



Operating Instructions

Refer to appropriate catalog bulletin and specification page for operating sequence applying to your specific valve. **Never operate valve until all essential allied equipment is operative and any necessary purges completed.** Failure of electro-mechanically operated valve to operate normally indicates that it is **not** powered. **Check this first!** Then check internal holding solenoid and/or motor operator.

Main system shut-off should always be accomplished with an upstream leak-tight manual fuel cock.

All Maxon valves react within a fraction of a second when de-energized. One cycle drop in electrically supplied power can cause this reaction.

All electro-mechanical manual reset valves may be operated manually when solenoid is electrically energized, but electrical tripping is recommended for normal shut-downs.

Electro-mechanical manual reset valves require two positive actions to open: a half rotation of handle to latch internal mechanism, and a reversed half rotation of handle to open valve. This refers to normally closed valves. With normally open valves, the procedure is the same, but the valve body position (i.e., open or closed) is opposite to the normally closed version.

Remotely located manual reset valves may be equipped with wheel-and-chain assembly. Instructions to operate the valve are on hand grip. Locate counterweight overhead at pipe level and hand grip can be brought down to convenient operating personnel height.

Normally closed motorized valves begin opening cycle immediately upon being powered; motor runs only until full open position is reached. Normally open valves begin to close immediately, and motor runs until fully closed position is reached.

Operator should be aware of and observe characteristic opening/closing action of the valve. Should operation ever become sluggish, remove valve from service and contact Maxon for recommendations.

Address inquiries to: Maxon Corporation, Muncie, IN 47302, Phone (765) 284-3304
FAX (765) 286-8394

Always include valve serial number and nameplate information to insure positive identification.



Contact Esys for more information about this product:
Esys® The Energy Control Company™
4520 Stine Road, Ste 7
Bakersfield, CA 93313
(661) 833-1902

email: esys@esys.us
website: <http://www.esys.us>



Maintenance Instructions

Maxon valves are endurance tested far in excess of the most stringent requirements of the various approval agencies. They are designed for long life even if frequently cycled, and to be as maintenance-free and trouble-free as possible.

Every Maxon valve is operationally tested and meets the requirements of ANSI B16.104 Class VI Seat Leakage when it leaves our plant.

Top assembly components require no field lubrication and should **never** be oiled.

Auxiliary switches, motors and solenoids, may be replaced in the field.

WARNING: Do not attempt field repair of valve body, top assembly or motor drive unit. Any alterations void all warranties.

Valve leak test, performed with valve in line as prescribed by jurisdictional authorities, is strongly encouraged and should be done on a regularly scheduled basis. In rare instances where valve shows leakage, perform **Pre-Operational Exercising** (see Installation Instructions) and retest. If leakage does not stop, remove valve from service.

Maxon valves are designed to be used with clean fluids. If foreign material is present in the fuel line, it will be necessary to inspect the valve to make certain it is operating properly. If abnormal opening or closing is observed, the valve should be removed from service. Contact your Maxon representative for instructions.

Insurance authorities agree . . .

. . . that the safety of any industrial fuel burning installation is dependent upon well-trained operators who are able to follow instructions and to react properly in cases of emergency. Their knowledge of, and training on, the specific installation are both vital to safe operation.

Safety controls may get out of order without the operator becoming aware of it unless shutdowns result. Production-minded operators have been known to bypass faulty controls without reporting the trouble.

Continued safe operation of any installation is then assured only if the plant management carefully develops an exact schedule for regular periodic inspection of all safety controls, insisting that it then be rigidly adhered to.

A main gas shut-off cock should be located upstream from all other fuel train piping components and used to shut off all flow of fuel for servicing and other shutdowns.

All safety devices should be tested at least monthly* and more often if deemed advisable. Periodic testing for tightness of manual or motorized shut-off valve closure is equally essential.

*per NFPA 86-Appendix B-4 (1995)

Operator should be aware of and observe characteristic opening/closing action of the valve. Should operation ever become sluggish, remove valve from service and contact Maxon for recommendations.

Address inquiries to: Maxon Corporation, Muncie, IN 47302, Phone (765) 284-3304
FAX (765) 286-8394

Always include valve serial number and nameplate information to insure positive identification.



Contact Esys for more information about this product:
Esys® The Energy Control Company™
4520 Stine Road, Ste 7
Bakersfield, CA 93313
(661) 833-1902

email: esys@esys.us
website: <http://www.esys.us>



Auxiliary Signal Switches Hermetically Sealed

Field Installation Instructions

NOTE: Instructions below are written for normally closed valves. For normally open versions (STO-MNI, STO-ANI, Fig. 1 & 2), reverse switch nomenclature. (VOS becomes VCS and vice versa.)

General: Shut off fuel supply upstream of valve, then de-energize valve electrically.

- Remove top or side cover to provide access, being careful not to damage gasket.
- Compare with illustrations at right to identify YOUR valve type.

To replace existing switches:

- Note wand position and mounting hole location carefully, then remove 2 screws and lift existing switch.
- Install replacement switch in same mounting holes on bracket and verify correct wand position.
- Replace existing wiring one connection at a time, following original route and placement.

To add switches to existing valve:

- Check illustrations at right. If your valve uses a switch mounting bracket as in Fig. 1 & 2, mount switches to bracket using the mounting holes appropriate for valve type and size.
- Position bracket so VCS wand just touches top of actuator, then move downward slightly, depressing wand until switch clicks, then tighten mounting screws to hold this position.
- Pin bracket by drilling 1/8" dia. holes 1/4" deep into bracket mounting pad through drive pin holes, then tap drive pin in until flush.
- Route wires to wiring compartment as shown, then complete wiring connections and clean out metal drilling chips from previous procedure.
- Cycle valve, checking switch actuation points carefully. (VCS actuates at top of stem stroke, VOS at bottom.) Simultaneously the valve body must be tested for switch continuity and seat leakage. Bend VOS switch wands slightly if necessary to insure valve is opening fully.
- Replace gasket and cover, then return valve to service.

Fig. 1
.75" – 3" NI
non-CP

Remove side cover plate. Switches mount on bracket. (See "A" below)

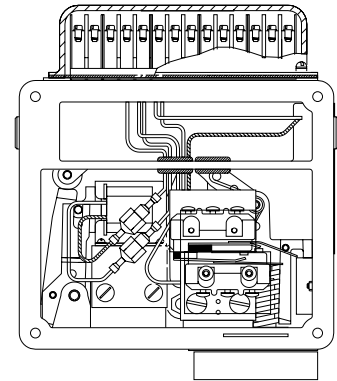
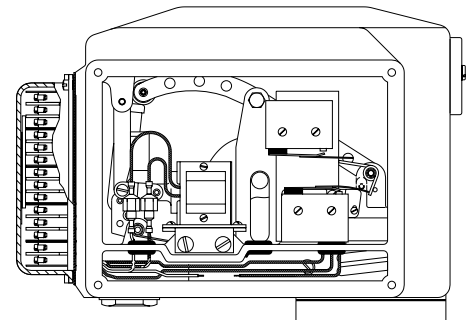

Fig. 2
2.5" – 4" NI-CP
6" 808NI

Remove side cover plate. Switches mount on bracket. (See "B" below)



Wand Position

VOS switch wand should be actuated from above.



VCS switch wand should be actuated from below.



Mounting Brackets

For 1", 1.25" C.I. & 2", 3" non-CP

VCS switch mounts on back of bracket

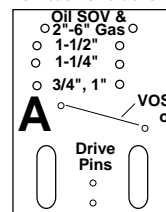

- 3", 4", 6" (-2)
- 3", 4", 6" (-2)
- 2-1/2" (-1)
- 2-1/2" (-1)

VCS Switch on back

B

VOS switch on front

Bracket Mounting Holes



Contact Esys for more information about this product:
 Esys® The Energy Control Company™
 4520 Stine Road, Ste 7
 Bakersfield, CA 93313
 (661) 833-1902

email: esys@esys.us
 website: <http://www.esys.us>



Electrical Data

Electro-Mechanical Valves

Normally Closed Valves

Manual Reset Series:

- .75" - 3" Series 808NI, 818NI (-S);
- 1" - 1.25" Series 730NI, 760NI (-S);
- 2.5" - 4" Series 808NI(-S)CP;
- 6" Series 808NI (-S)

Automatic Reset Series:

- .75" - 3" Series 5000NI (-S);
- 1" - 1.25" Series 4730NI, 4760NI (-S);
- 2.5" - 4" Series 5000NI(-S)CP

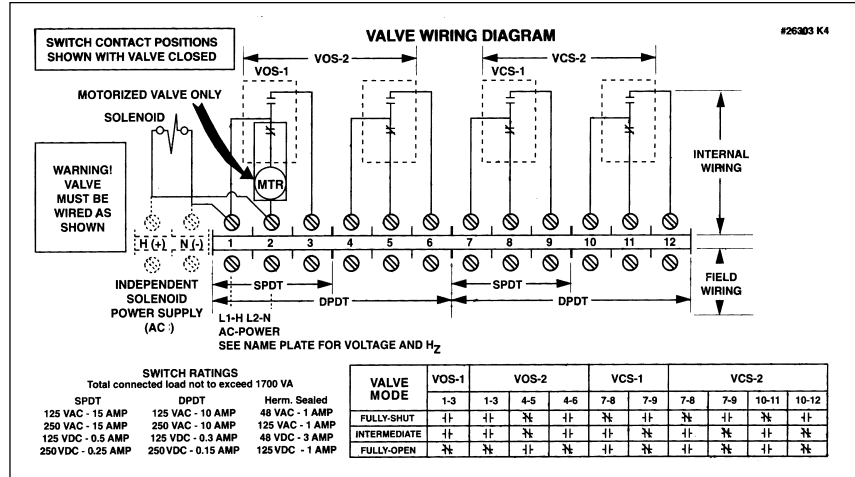

Normally Open Valves

.75" - 2" Series STO-MNI & STO-ANI (-S)

2.5" - 4" Series STO-MNI-CP & STO-ANI(-S)CP

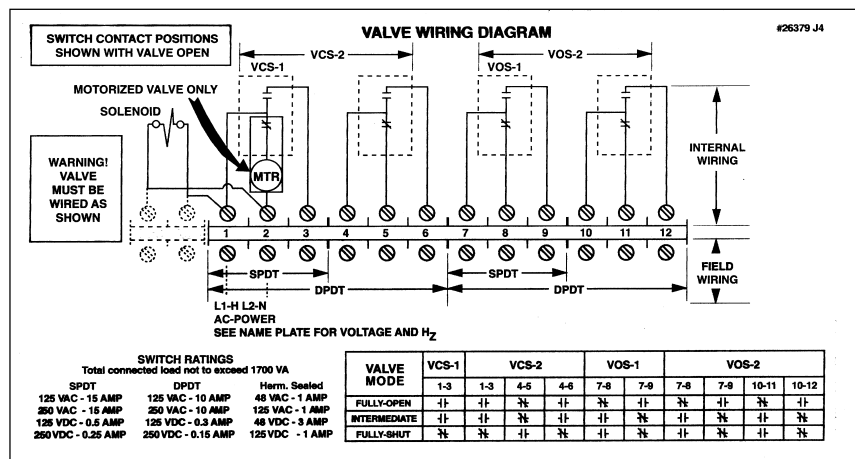

Contact Esys for more information about this product:
 Esys® The Energy Control Company™
 4520 Stine Road, Ste 7
 Bakersfield, CA 93313
 (661) 833-1902

email: esys@esys.us
 website: <http://www.esys.us>



Tandem Arrangements

(for simultaneous opening of main and blocking valves)

Installation Instructions

Review and comply with all general valve installation instructions provided separately. (See sketch below.)

1. Mount both valves in fuel line with center to center spacing as originally specified, and blocking valve (without handle) downstream of main valve (with handle).
2. Check valve alignment to be certain that operating wheels lie in the same plane.
3. Remove tape from the wheel of the main valve and unwind the attached chain. Do not remove the screw holding chain to wheel; it has been factory positioned to assure correct alignment. Do not remove tension spring attached to one end of chain or the wooden block insert which preloads the spring.
4. Take free end of chain and loop it around the wheels of both main and blocking valve as shown in sketch below. Depending on the specific valve series and arrangement, tension spring may be located either above or below the wheel center-line.
5. Draw free end of chain and tension spring together so that as much slack as possible is eliminated, then insert the open eye of the spring "S" hook through the link in the chain that will most nearly maintain this position.
6. Crimp the "S" hook shut around the chain link, then cut and discard excess chain.
7. Remove spring preload wood block insert from the tension spring, and verify that the chain is drawn tight.
8. Rotate the operating handle of the main valve fully to latching position for your particular valve, then hold handle firmly in this position while performing the next few steps.
9. Rotate blocking valve wheel fully counter-clockwise until it strikes a stop (it will slide within the loop of chain).
10. Still holding main valve wheel in place, move blocking valve wheel approximately 1/4 to 1/2 inch back in the clockwise direction. Insert the #10-24 X 1/2" screw (furnished) through the chain link that lines up with the tapped hole on bottom of blocking valve wheel, then fasten securely.
11. Verify that the valves are wired in parallel as shown in wiring schematic on page 6219.

To add wheel & chain assembly to existing tandem valves:

1. Verify that both valves are in the same top assembly position (TO or AW). Rotate if necessary. (See top assembly rotation instructions on pages 6200-S-3 and 6200-S-4.)
2. Bend handle of main valve outward about 25°.
3. Cut off handle of blocking valve at outer wheel face.
4. Remove hardware holding main valve wheel in place and mount new wheel and spacer to the existing wheel with new hardware provided.
5. Cut chain loop to the desired length and secure to both wheels.

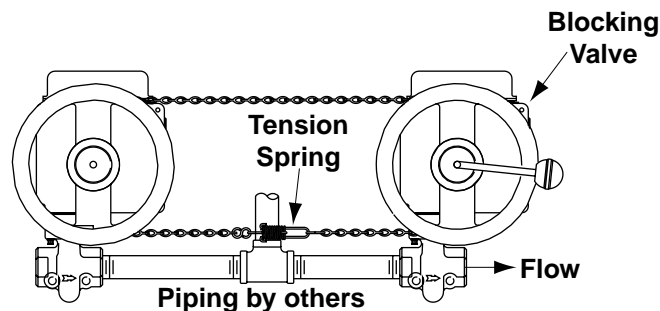

Contact Esys for more information about this product:
 Esys® The Energy Control Company™
 4520 Stine Road, Ste 7
 Bakersfield, CA 93313
 (661) 833-1902

email: esys@esys.us
 website: <http://www.esys.us>



Overhead Wheel & Chain Assembly

Overhead wheel and chain assembly allows operation of a manual reset valve in an otherwise inaccessible overhead location. A wheel is mounted onto the handle of the valve. The attached chain is weighted on one end and has a paddle handgrip on the other.

Once the valve is electrically energized, pulling down on the paddle will open normally closed versions or close normally open versions.

Maxon valve's free-handle design permits valve to trip to its rest position on any power interruption.

Wheel and chain assembly includes a length of chain to position the paddle handgrip slightly below pipe centerline. A standard length of 7 feet of chain is included with CP and larger valve sizes and 5 feet is included with all other valves. Extra chain (in one foot increments) may be specified to fit your specific location.

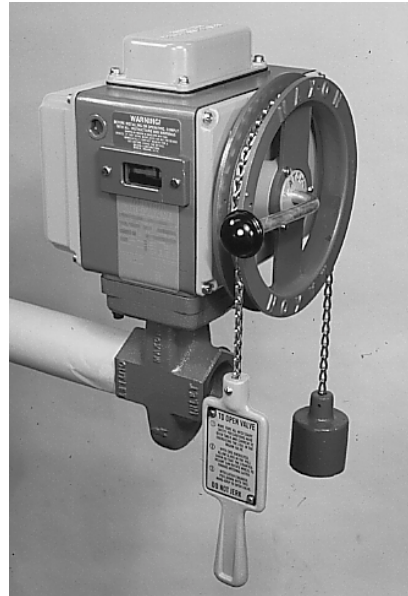

Approximate envelope dimensions *(nominal, in inches)*

Swinging gate valves

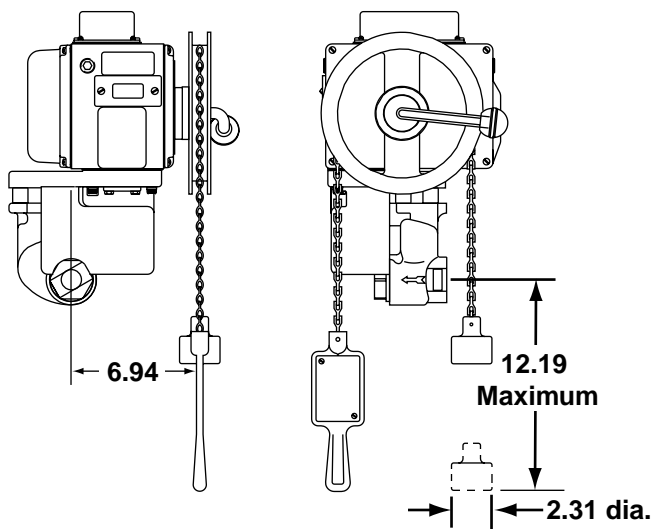

Rising stem valves

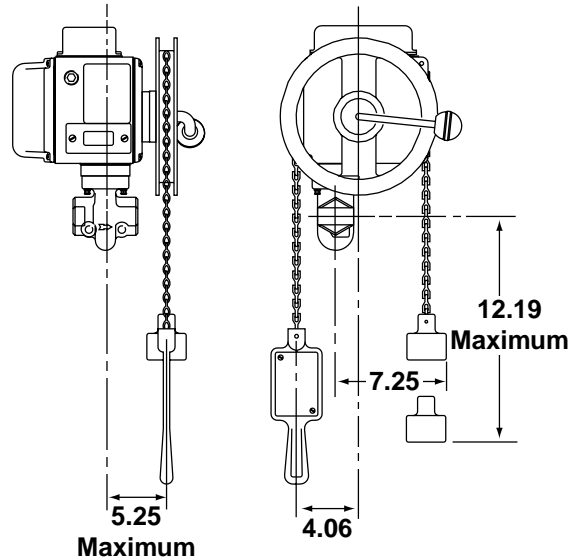

NOTE: Overhead wheel & chain can only be mounted on swinging gate valves with the top assembly position TO.



Contact Esys for more information about this product:
 Esys® The Energy Control Company™
 4520 Stine Road, Ste 7
 Bakersfield, CA 93313
 (661) 833-1902

email: esys@esys.us
 website: <http://www.esys.us>



Maintenance Instructions

CAUTION: Valve leak testing should be undertaken only by trained and experienced personnel. Instructions provided by the company and/or individuals responsible for the manufacture and/or overall installation of complete system incorporating Maxon valves take precedence over these provided by Maxon. If Maxon instructions conflict with any codes or regulations, contact Maxon Corporation before attempting this procedure.

Valve leak test should be performed on a quarterly basis to assure continued safe and reliable operation. Each valve should be checked with available line pressure. Absolute zero leakage may not be obtained in the field. Any valve that exceeds the allowable leakage, as set forth by your local codes or insurance requirements (15 bubbles per minute), should be removed from service and your Maxon representative should be contacted.

Every Maxon valve is operationally tested and meets the requirements of ANSI B16.104 Class VI seat leakage when it leaves our plant.

Suggested leak test procedure for double-blocking shut-off valves (without vent line)

- (a) Shut down combustion system per manufacturer's recommended procedure.
- (b) Close manual valves A and B.
- (c) Visually inspect to verify that shut-off valves #1 and #2 are closed.
- (d) Remove the 1/4" pipe plug from downstream side of shut-off valve #1. Install leak test apparatus. Safely vent any trapped gas pressure.
- (e) Open manual shut-off valve A, then close leak test apparatus. Insert tube into a container of water just below the surface.
- (f) Open test apparatus and test valve for leakage. As a guideline, valve should be tested for 2 minutes per inch of pipe diameter. Large diameter pipes or long piping runs between shut-off valves may need additional testing time.
- (g) If valve testing indicates leakage exceeding 15 bubbles per minute, perform pre-operational exercising as outlined on Page 6200-S-2 and retest the valve. If valve continues to exceed allowable leakage limit, remove from service and contact Maxon.

Example of a gas piping diagram for leak test

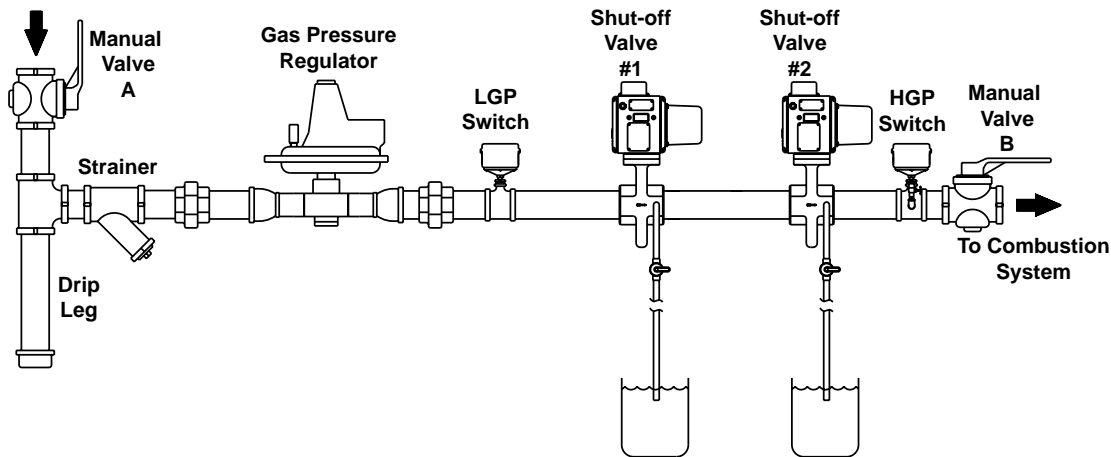

Example of a wiring diagram for leak test

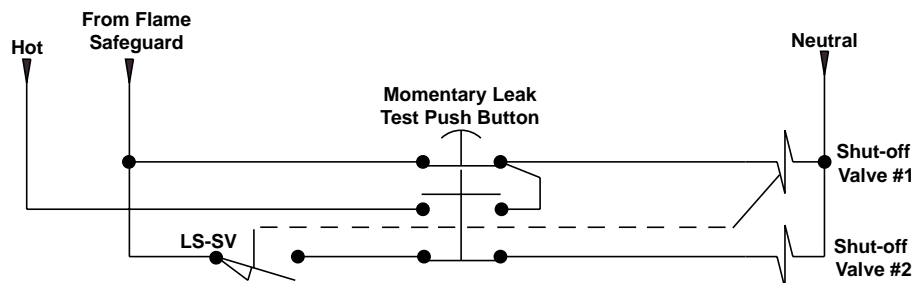

NOTES:

Push button must be tamper resistant.

LS-SV – Closes when Shut-off Valve #1 is fully open.

The "From Flame Safeguard" line is energized only when all conditions for safe operation have been satisfied.



Contact Esys for more information about this product:
 Esys® The Energy Control Company™
 4520 Stine Road, Ste 7
 Bakersfield, CA 93313
 (661) 833-1902

email: esys@esys.us
 website: <http://www.esys.us>



Maintenance Instructions

Suggested leak test procedure for double-blocking shut-off valves (without vent line) - *continued*

- (h) Secure test apparatus on valve #1.
- (i) Remove the 1/4" pipe plug from downstream side of shut-off valve #2. Install leak test apparatus.
- (j) With an auxiliary power supply connected to valve #1, open test apparatus and test valve for leakage. As a guideline, valve should be tested for 2 minutes per inch of pipe diameter. Large diameter pipes or long piping runs between shut-off valves may need additional testing time.
- (k) If valve testing indicates leakage exceeding 15 bubbles per minute, perform pre-operational exercising as outlined on Page 6200-S-2 and retest the valve. If valve continues to exceed allowable leakage limit, remove from service and contact Maxon.
- (l) Secure test apparatus on valve #2.
- (m) Upon completion of valve leak testing, test all other safety interlocks per manufacturer's instructions and verify they are operational.
- (n) Restore combustion system to operational condition. Be sure to remove all auxiliary power supplies and jumpers that may have been used during testing.

Suggested leak test procedure for double-blocking shut-off valves with vent line

Example of a gas piping diagram for leak test with vent line

If vent valve is present, use auxiliary power supply to power vent valve to closed position during this test procedure. Follow test instructions above. Once test is complete, be sure vent valve is restored to normal operation.

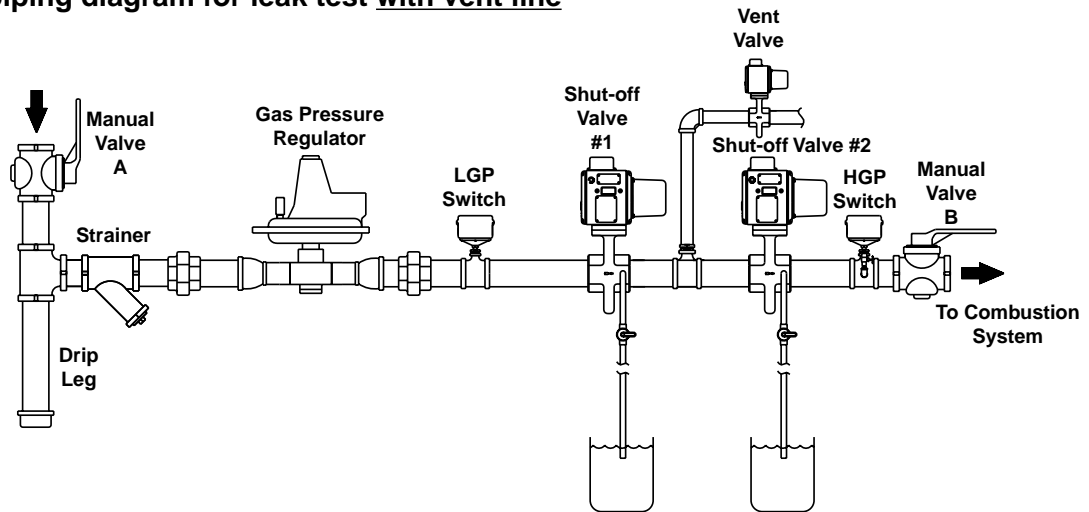

Example of a wiring diagram for leak test with vent line

NOTES:

Push button must be tamper resistant.

LS-VV – Closes when Vent Valve is fully closed

LS-SV – Closes when Shut-off Valve #1 is fully open.

The "From Flame Safeguard" line is energized only when all conditions for safe operation have been satisfied.

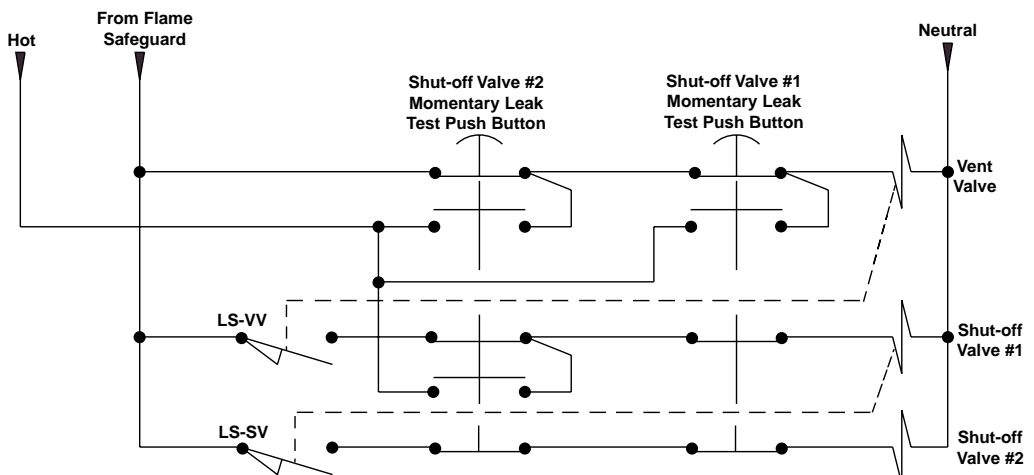

Contact Esys for more information about this product:
 Esys® The Energy Control Company™
 4520 Stine Road, Ste 7
 Bakersfield, CA 93313
 (661) 833-1902

email: esys@esys.us
 website: <http://www.esys.us>

