

Installation Instructions

General

These mounting instructions for LO-NOX™ Line Burners are in addition to the **general AIRFLO® Line Burner installation instructions** published on Maxon catalog pages 5000-S-1 through 5000-S-10.

Specific instructions are also offered for other Maxon component items:

- **Shut-Off Valves** (pages 6000-S-1 through S-14)
- **Flow Control Valves** (pages 7000-S-1 through S-4)
- **Mixing Tubes** (pages 3200-S-1 through S-6)

Read complete instructions before proceeding, and familiarize yourself with all the system's equipment components. Verify that your equipment has been installed in accordance with the original manufacturer's current instructions.

Clean fuel lines are essential to prevent blockage of pipe train components or burner gas ports. All dirt, scale and pipe dope should be blown out of any new gas line before actually connecting to the burner system.

Main gas shut-off cock should be upstream of both main gas regulator and pilot line take-off. Use it to shut off fuel to both pilot and main burner during shutdown periods of more than a few hours. **MICRO-RATIO® Control Valves are not intended for tight shut-off.**

Main gas regulator is essential to maintain a uniform system supply pressure. A separate regulator should be provided in the branch leading to each burner system if more than one is served by a common main. Size regulator for full system capacity at required pressure, including pipe train losses. Follow the instructions attached to the regulator during installation.

Pilot take-off should be upstream of main gas regulator but downstream of main gas cock. It should normally include its own pilot gas regulator (selected to meet pilot flow and pressure needs), a solenoid valve and shut-off cock. An adjustable gas orifice at the pilot inlet simplifies adjustment.

Appropriate pilots should be provided which are compatible with the type of burner and control system being used.

Fuel shut-off valves (when properly connected to a safety control system) shut the fuel supply off with a loss of electrical power. **Manual reset valves** require operator attendance each time the system is started up (or restarted after a shut-down). **Motorized shut-off valves** permit automatic start/restart when used with appropriate control system.

Test connections are essential for burner adjustment. At a minimum, they should be provided downstream of any mixing tube and at each burner inlet. Test connections should never be installed in elbows or pipe tees. **Test connections must be plugged except when readings are being taken.**

Bolt Torque Tightening

1. Apply Never-Seez (anti-seize and lubricating compound) to the threads of the bolts to improve the pre-loading of the gasket.
2. Tighten the bolts to 1/2 the specified value (see table below), starting at position 1 and working to position 6.
3. Tighten the bolts to the full torque value, starting at position 1 and working to position 6.
4. Tighten the bolts again to the full value starting at position 1 and working to position 6.

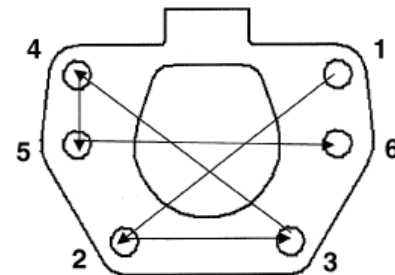

Torque Values

Bolt Size	Bolt Material	Torque Value	Units
M10	Plated steel	186	in lbs
M10	Stainless steel	248	in lbs
M10	Inconel 718	45	ft lbs



Contact Esys for more information about this product:
 Esys® The Energy Control Company™
 4520 Stine Road, Ste 7
 Bakersfield, CA 93313
 (661) 833-1902

email: esys@esys.us
 website: <http://www.esys.us>



Installation Instructions

Premixed Air/Gas Manifolding Suggestions

1. Always design air/gas manifold piping for **uniform** distribution to multiple-feed or multiple-burner systems. **Select manifold piping sizes by starting at the burner/nozzle end and working backward to the premixer discharge.**
2. Always make sure that any distribution header is greater in cross-sectional area than the **total** cross-sectional area(s) of any and all pipes being fed.
3. **Never** install a throttling or shut-off device in any air/gas mixture line between the premixing device and its burner(s).

The chart below gives typical pipe data for use in designing air/gas distribution manifolds.

General Pipe Data

Nominal Pipe Diameter	Inside Diameter (inches)	Outside Diameter (inches)	Inside Area (square inches)
1/8	0.269	0.405	0.057
1/4	0.364	0.54	0.104
3/8	0.493	0.675	0.191
1/2	0.622	0.84	0.304
3/4	0.824	1.05	0.533
1	1.049	1.315	0.864
1-1/4	1.38	1.66	1.496
1-1/2	1.61	1.9	2.036
2	2.067	2.375	3.356
2-1/2	2.469	2.875	4.788
3	3.068	3.5	7.393
3-1/2	3.548	4	9.887
4	4.026	4.5	12.73
5	5.047	5.563	20.006
6	6.065	6.625	28.89
8	7.981	8.625	50.027
10	10.02	10.75	78.854
12	12	12.75	113.097

Sketch below shows four inlets being fed from one end-fed header. Note that full premixture manifold size is continued past all burner take-offs, and outlet extended and capped one pipe diameter length beyond last take-off. Always keep premixer device a minimum of four pipe diameters in length from first take-off.

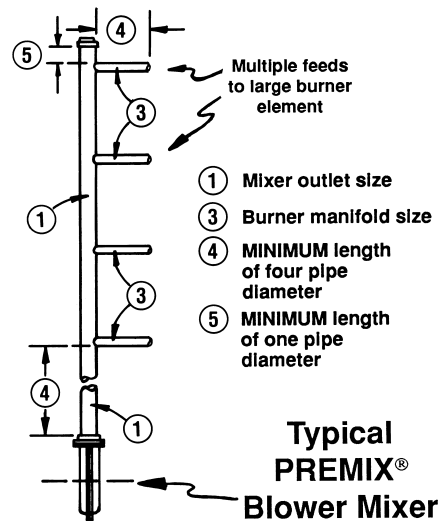

Start-Up Instructions

A fully premixed air/gas mixture must be supplied to your LO-NOX™ Burner to support proper combustion. With “fully-premixed” LO-NOX™ Burner systems, a Series “HG” Mixing Tube with MICRO-RATIO® Control Valve is often used to premix gas and air prior to its introduction to the LO-NOX™ Line Burner assembly.

A typical “HG” Mixing Tube system piping layout is illustrated below.

“HG” Mixing Tube System

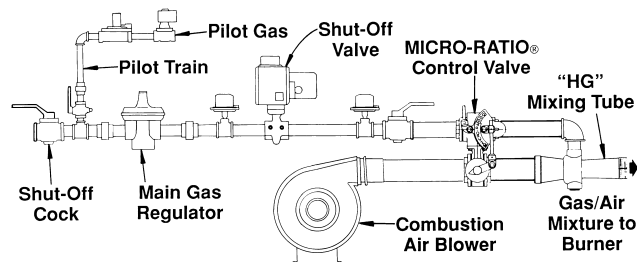

Maxon assumes no responsibility for the use or misuse of the piping layout shown. Specific piping and wiring diagrams should always be submitted to the appropriate agencies for approval on each application.

Combustion air blower provides the air (oxygen) supply to your combustion system and is essential to the mixing of fuel gas. It should be located in the coolest, cleanest position that you can find near the burner itself. It must not be exposed to direct radiant heat or positioned where it might draw in the inert gases or hot air rising from a furnace or oven. If problems exist, consider filters, relocation and/or ducting of an outside fresh air supply.

Minimize combustion air pressure drop between blower and mixing tube. Keep a minimum straight run of four pipe diameters into the mixer air inlet. Downstream piping from mixer to burner should be kept as short as possible.

Electrical service must match the voltage, phase and cycle of all electrical system components and be compatible with burner nameplate ratings. Insure that all normal control safeguards are satisfied. Combustion air blower should continue to run after shutdown to allow burner to cool.

Gas supply piping must be large enough to maintain the required fuel pressures cataloged for the particular burner size used with burner operating at full-rated capacity.

Natural gas pressure generally required (as measured at the mixer gas inlet) is 1 PSIG higher than air pressure for “HG” Mixing Tubes.

Anything more than minimal distance or piping turns may necessitate “oversizing” piping runs to keep pressure drops within acceptable ranges.

Inlet pipe leading to any burner should be at least four pipe diameters in length. If multiple burners are fed from a single gas train, care should be taken to minimize pressure drop and give maximum uniformity.

CAUTION: Do not install any shut-off device in the air/gas mixture line.

For initial burner start-up of LO-NOX™ premixed gas burner system:

CAUTION: Initial adjustment and light-off should be undertaken only by trained and experienced personnel familiar with combustion systems, with control/safety circuitry and with knowledge of the overall installation. Instructions provided by the company and/or individuals responsible for the manufacture and/or overall installation of complete system incorporating Maxon burners take precedence over these provided by Maxon. If Maxon instructions conflict with any codes or regulations, contact Maxon Corporation before attempting start-up.

- 1. Close all burner fuel valves or cocks.** Make preliminary adjustments to fuel gas regulators. Remove pilot and main gas regulators' adjusting screw covers. Turn adjusting screw down (clockwise) to approximately mid-position. Close pilot gas adjustable orifice screw by turning in clockwise until it stops. (Do not over-tighten.) Then back out the adjustable orifice (counterclockwise) approximately 2-3 turns.
- 2. Check all electric circuitry.** Verify that all control devices and interlocks are operable and functioning within their respective settings/ranges. Be sure all air and gas manifolds are tight and that test ports are plugged if not being used.
- 3. Check that all duct and chamber dampers are properly positioned** and locked into operating positions.

Start-Up Instructions

Initial start-up adjustment should only be accomplished during a “manual” burner control mode.

4. **Disconnect the automatic control motor’s linkage from your MICRO-RATIO® Control Valve’s operating crank arm (or from your Maxon Control Valve)** by loosening the control motor’s connecting rod from the valve’s toggle linkage. Manually set and secure control valve in its “minimum” position.
5. **Start all system-related fans and blowers.** Check for proper blower motor rotation and impeller direction. Verify that all control interlocks are working. Allow air handling equipment to run for adequate purge of your manifolds and combustion chamber plenums. With main gas shut off, manually advance MICRO-RATIO® Control Valve’s operating crank to “high fire” position so that air only flows through burner and combustion chamber.

CAUTION: Do not by-pass control panel timers typically controlling sequential operations.

6. **Check minimum mixture pressure** at burners by turning the MICRO-RATIO® Control Valve to its minimum position and reading differential air pressure only at each burner with a water column manometer. Any reading below 0.10" wc differential (natural gas) requires re-adjustment as described below.

Setting minimum mixture pressure with a MICRO-RATIO® Control Valve and Series “HG” Mixing Tube system:

If minimum mixture pressure must be increased, open the MICRO-RATIO® air valve slowly (by turning toward higher-numbered positions) until the required differential air (mixture) pressure is reached, then mark air valve dial at the position opposite pointer. This point will become the minimum air setting for your MICRO-RATIO® Valve mixing tube system.

Continue opening the MICRO-RATIO® air valve while watching the manometer connected into the burner’s air/gas mixture manifold. Determine the point at which further opening of the air valve gives no appreciable increase in air pressure within the manifold/burner. Mark the air valve dial at this position opposite the air valve pointer. This point will become the maximum air setting for your MICRO-RATIO® Valve mixing tube system.

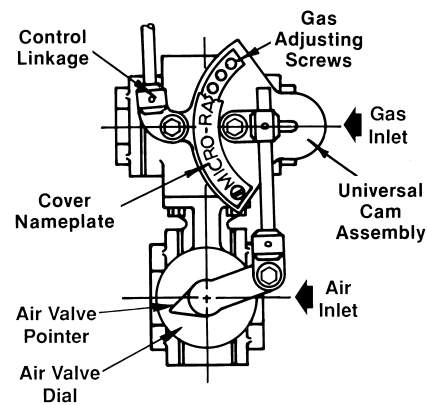
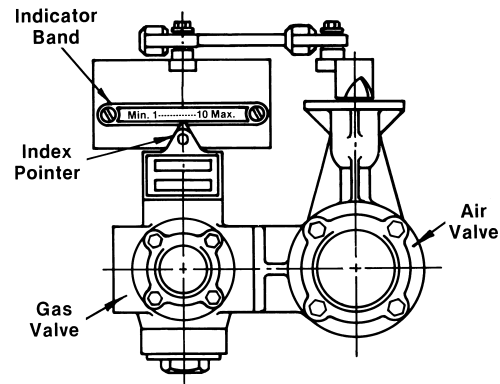

Having marked and/or recorded the MICRO-RATIO® Control Valve’s air valve settings for both minimum and maximum firing positions, you may adjust the linkage and travel of the gas valve’s stroke (see sketch below).

Loosen Allen set screw “A” and binding screw “B” in toggle “C”. Move the toggle in universal cam assembly slot towards the center of rotation so that gas valve can rotate from its minimum to maximum position, while the air valve swings between the established (and marked) minimum and maximum settings.

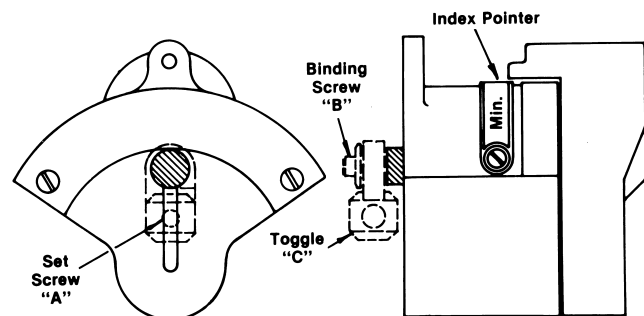

Start-Up Instructions

Place air valve on pre-determined “minimum” position and rotate gas valve to its “minimum” setting position. Tighten down set screw “A” and binding screw “B” with both valves set at “minimum”.

Establish set screw “A” as minimum-end adjustment point and binding screw “B” as maximum-end adjustment point. (Note: It doesn't matter which is maximum or minimum, as long as you identify and keep the same reference points for the next adjustment steps.)

Now rotate MICRO-RATIO® Valve to “maximum” position. The air valve maximum setting was previously determined. Loosen binding screw “B” and adjust pointer and linkage to correct just half the distance required to make the air valve pointer indicate the maximum air valve setting.

Re-tighten binding screw “B” and return the MICRO-RATIO® Valve to the “minimum” air setting.

This time, loosen set screw “A” and again correct for just half the distance required to make the air valve pointer indicate the minimum air valve setting.

Re-tighten set screw “A” and again return the MICRO-RATIO® Valve to its maximum position.

Similarly, correct one half the distance with binding screw “B” for the maximum setting, etc.

Continue this adjustment procedure until the gas and air valves reach their minimum and maximum positions simultaneously. Normally, this is accomplished within seven adjustments.

7. **Remove cover plate** from screw carrier cam assembly and turn all adjusting screws counter-clockwise until flush with outer surface of casting (new equipment is shipped this way).
8. **Open main and pilot gas cocks** and light first burner pilot following instructions appropriate for that burner and pilot type. If multiple pilots are used, open individual cocks and adjust each in turn.

To light and adjust gas pilot: Check to insure pilot combustion air supply is flowing to any pressure pilot mixer. Pilot gas regulator should initially be set at approximately midpoint of its adjustment range. With pilot gas solenoid closed, open main fuel gas and pilot gas cock. Energize spark ignitor and pilot gas solenoid. Observe pilot ignition through sight port of pilot assembly and/or by viewing micro-amp signal metered from flame safeguard relay circuit.

Refine pilot setting for a hard blue flame (and/or strongest micro-amp signal) by adjusting gas flow through pilot orifice and/or pilot regulator.

Shut off pilot gas cock to extinguish pilot fire. Re-open and confirm easy re-ignition several times. The flame safeguard relays should now power the main fuel shut-off valves.

9. **Light main burners at minimum** as follows:
First, turn MICRO-RATIO® Valve to its minimum setting (which may be at position 1 or 2 after completing step 6), then open fuel shut-off valve and turn corresponding screw in (clockwise) until flame ignites across burner face. (This may take several turns of the screw.)
NOTE: At this point, it is more important to get any kind of a flame as soon as possible. The flame geometry can be adjusted and refined as needed later.
A good minimum fire should provide uniform flame across the entire burner face, contained within the zipper flame channel at the base of burner mixing plates. Any thin spots or gaps indicate uneven air velocity over the burner which must be corrected or a higher minimum fire established by continuing to turn in on the minimum stop screw.
10. Once your flame is established and refined at this position, and without advancing the screw carrier quadrant higher, screw all remaining screws down to at least the same level as your first adjusted screw.

Once the gas is applied to the burner, you may find that a LOUD howling is set-up by the duct system. This howling means that the burner is firing too rich. Back out on the gas screws and the noise will stop. The burner is then adjusted so that the flame is lean. You will know you have adjusted the burner too lean if the flame fails to cross ignite across the face.

NOTE: A preliminary setting can be established with all the remaining adjusting screws. Generally, each succeeding screw needs to be screwed in approximately one full turn more (clockwise) than its preceding screw. A smooth “stair-step” gradient pre-set at this point from low to high will simplify the remaining adjustment steps.

Start-Up Instructions

CAUTION: If flame is extinguished, immediately return MICRO-RATIO® Control Valve to minimum position and shut off fuel (if flame safeguard has not already done so). Turn in slightly on adjusting screw at point where ignition was lost, then return valve to minimum position, re-establish pilot, open fuel valve and verify ignition.

11. Without advancing the valve quadrant, screw down clockwise on #2 screw (one or two turns). Then slowly advance the screw carrier quadrant to the #2 position. Adjust flame appearance at this new position #2.

NOTE: If firing chamber is of refractory construction, allow your burner system to operate at this low setting for the necessary dry/cure-out time period recommended by the chamber or refractory manufacturer. Then continue adjustments of valve.

12. Again, without moving valve, bring #3 and all remaining adjusting screws down to the same level as #2 screw.

NOTE: If approximate pre-set gradient was made earlier, the remaining screws will already be at or below appropriate levels.

Progressively work your way up through each adjusting screw position, developing a smooth progression slope from your first screw to the "maximum" position.

As each is adjusted, you must turn the remaining unadjusted screws in at least that far to prevent possible damage to flexible cam strips inside the screw carrier cam assembly.

Turning a screw in "clockwise" gives more gas at that setting; turning it out gives less.

NOTE: To adjust the flame at any position, you must move the valve quadrant to the number you desire to adjust. This aligns the adjusting screw directly on top of the fuel valve plunger. A resulting adjustment of the screw is directly applied to the fuel valve plunger and its interconnected valve body linkage.

Observe flame characteristics carefully.

Flame should remain a bright blue color with a length beyond the mixing plates as indicated in capacity/specification data. If flame becomes long and yellow, gas pressure is too high and/or air velocity is too low.

NOTE: Dust and/or chemicals entrained into passing air stream may affect physical color of flame. In this case, adjust burner for stable flame shape and geometry.

To measure mixture pressure, connect water column (manometer) to the test connection in burner's end plate. **To determine air velocity,** use a velometer at the profile opening. Correct velocities by increasing or decreasing profile opening size.

If flame is too short, gas pressure may be too low and should be increased, or velocities are too high and may need to be decreased.

NOTE: Air velocities should be measured only when the fan is handling air at the desired control temperature.

13. **Cycle burner from minimum to maximum** and refine adjustment, if necessary.

For operation with interrupted pilot (as recommended), shut off pilots and cycle burner from minimum to maximum and back several times to verify the flame is maintained.

CAUTION: After completing previously listed steps, check all interlocking safety components and circuitry to prove that they are properly installed, correctly set, and fully operational. If in doubt, shut the system down, close main and pilot cocks, and contact responsible individual before proceeding further.

14. **Reconnect linkage to control motor,** plug all test connections, replace equipment cover caps and tighten linkage screws.
15. **Check out overall system operation** by cycling through light-off at minimum, interrupting pilot, and allowing temperature control system to cycle burner from minimum to maximum and return.

Re-check all safety system interlocks for proper setting and operation.

WARNING: Test every UV installation for dangerous spark excitation from ignitors and other possible sources of direct or reflected UV radiation. Use only gas-tight scanner connections.

16. **Before system is placed into full service,** instruct operator personnel on proper start-up, operation and shut-down of system. Establish written instructions for their future reference.