

LO-NOX™ Line Burners

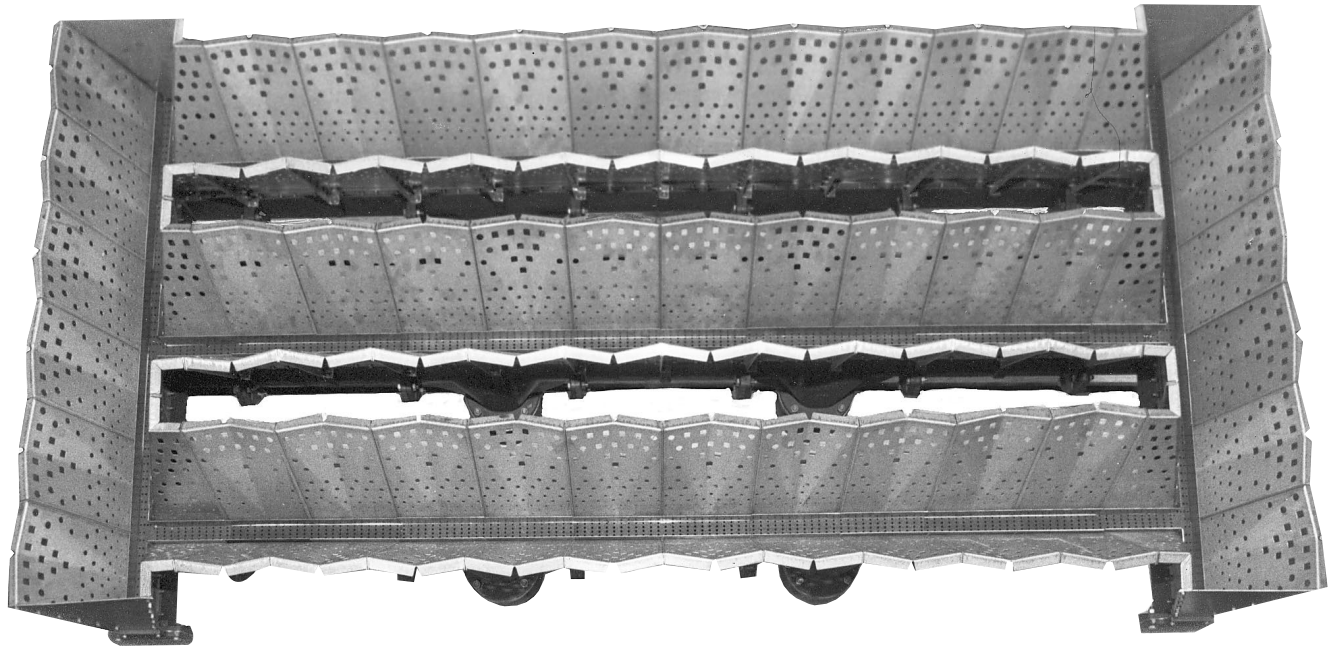

24 lineal feet assembly of LN4-12-G LO-NOX™ Burner including end plates and pilot assembly

- **Provides direct-fired, in-the-duct, process air heating** with greatly reduced generation of NOx
- **Burns clean and odor-free** with most low pressure gaseous fuels
- **Direct-firing optimizes heat transfer efficiencies.** All available heat from the gaseous fuel is released directly into the passing air stream.
- **Modular burner design** permits shaping the burner element and total heat release to match your specific application's requirements. Basic building block concept provides infinite number of possible burner configurations to meet your needs.
- **Long service life and lower maintenance cost** result from rust-resistant iron burner bodies and the controlled expansion of stainless steel mixing plate's design
- **High turndown ratio promotes application flexibility** for all fresh or recirculated air stream heating

Covered by U.S. Patents #25,626, #3,297,259 and #4,573,907;
Canada #786,136 and #786,137; Great Britain #943,733



Contact Esys for more information about this product:
Esys® The Energy Control Company™
4520 Stine Road, Ste 7
Bakersfield, CA 93313
(661) 833-1902

email: esys@esys.us
website: <http://www.esys.us>



Design and Application Details

Principle of Operation

LO-NOX™ Line Burners are designed for heating process air-in-motion and consist of a rust-resistant iron body (which serves as the air/fuel manifold), drilled to discharge the fuel/air mixture between diverging stainless steel or Hastelloy-X mixing plates.

The entire burner assembly is mounted inside your duct directly in the air stream being heated. The air stream passes across the burner and through the mixing plates. Carefully controlled mixing plate aeration patterns give progressive mixing, superior cross-ignition and flame retention across the entire burner assembly length. The LO-NOX™ Line Burner burns clean and odor-free with extremely low levels of NOx production.

Accurate air/fuel ratio and air velocities with resulting duct static pressure drop are the key to successful operation. They are established by the use of a customer-installed profile plate within the duct.

A minimum profile plate width of 6" is required surrounding all LO-NOX™ Line Burner assemblies.

Optimum burner performance and maximum service life demands that air stream velocities be uniform across the entire burner assembly.

Normal capacities vary widely with applications. Fuel used and design velocities affect turndown. Modular design permits shape and total heat release to match your application needs.

Performance data varies depending upon temperature of air upstream and downstream of burner assembly, the percent of oxygen (by volume) in the passing air stream, and the allowable duct static pressure drop (which relates to velocity of air across the burner).

Combustion Air Requirements

Combustion air blower should be sized for an air/fuel ratio of 14:1.

CAUTION: A variation in excess of $\pm 25^{\circ}\text{F}$ combustion air temperature can affect NOx level production and/or cross ignition of a LO-NOX™ Burner. Locate air inlet of combustion air blower in area where incoming air temperature is relatively constant.

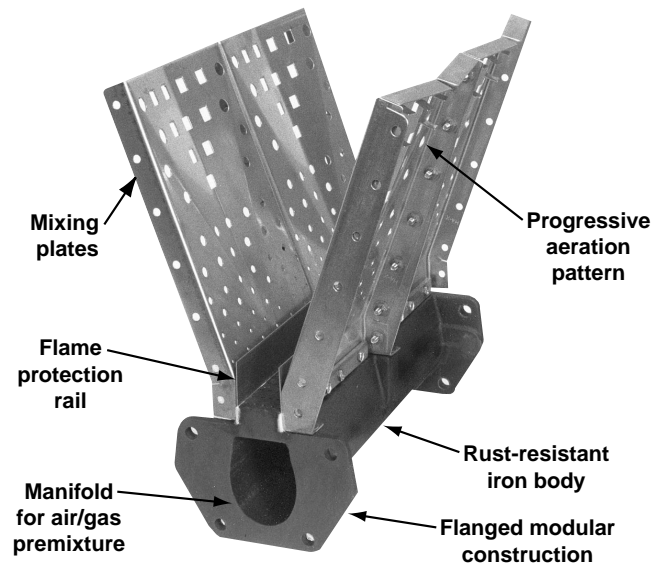

LO-NOX™ Line Burners are part of a complete burner system designed and proven to give low formation of oxides of nitrogen.

A complete LO-NOX™ Burner system normally includes a gas train, proportioning/mixing equipment, combustion air supply, and a combustion control panel. Your Maxon representative can help you choose from the broad range available.

LO-NOX™ Line Burners are offered in three different types. Each type is optimized for a specific type of application. All require a full air/gas premixture and are intended for use in heating process air in motion with maximum inlet air temperatures up to 800°F (427°C):

- **LN-3 LO-NOX™ Line Burners** have iron bodies and #321 stainless steel mixing plates and require an air/gas premixture system and/or outlet temperatures up to 1000°F (538°C).
- **LN-4 LO-NOX™ Line Burners** have iron bodies and #310 stainless steel mixing plates as above for applications with outlet temperatures up to 1500°F (816°C).
- **LN-5 LO-NOX™ Line Burners** compliment their iron bodies with Hastelloy-X mixing plates for use in applications with up to 1700°F (927°C) outlet temperature requirements.

Contact Esys for more information about this product:
 Esys® The Energy Control Company™
 4520 Stine Road, Ste 7
 Bakersfield, CA 93313
 (661) 833-1902

email: esys@esys.us
 website: <http://www.esys.us>

